

**THE COUNCIL OF THE CITY AND COUNTY OF SWANSEA  
CYNGOR DINAS A SIR ABERTAWE  
TRAFFIC REGULATION ORDER 2024  
VARIOUS RESTRICTIONS – UPLANDS WARD  
NOTICE 2024**

**NOTICE:** is hereby given that on 24<sup>th</sup> May 2024 The Council of the City and County of Swansea made the above order under the Road Traffic Regulation Act 1984 (as amended) and of all other enabling powers. The order will be effective from 6<sup>th</sup> June 2024, as set out in the schedules below. A copy of the order and plan may be inspected during office hours at the Civic Centre, Oystermouth Road, Swansea, SA1 3SN. Any person wishing to challenge the validity of the order or procedures used in making this order may apply to the High Court within 6 weeks of the date the order was made.

**SCHEDULES**

**SCHEDULE 1**

**REVOCATIONS**

The existing Orders are revoked as far as they are inconsistent with the proposals hereinafter contained which relate to the length or lengths of the road or roads referred to in the schedules hereto.

**SCHEDULE 2**

**PROHIBITION OF WAITING AT ANY TIME**

**HAWTHORNE AVENUE**

On its southern side from its junction with the northern kerblines of Hazel Road west ward for a distance of 6 metres.

**HAZEL ROAD**

On its northern side from its junction with the southern kerblines of Hawthorne Avenue west ward for a distance of 6 metres.

**HAWTHORNE AVENUE**

On its southwestern side from its junction with the northern kerblines of Pinewood Road northwest for a distance of 6 metres.

**PINEWOOD ROAD**

On its northern side from its junction with the southwestern kerblines of Hawthorne Avenue west for a distance of 6 metres.

**BERNARD STREET**

On both sides, from its junction with the northern kerblines of Glanbrydan Avenue for a distance of 10 metres north.

## **GWYDR CRESCENT**

On its southern side from its junction with eastern kerblines of Rhyddings Park Road to its junction with the western kerblines of Rhyddings Park Road rear lane, a distance of 29 metres.

On its northern side from its junction with the western kerblines of Rhyddings Park Road rear lane for a distance of 3 metres west.

## **RHYDDINGS PARK ROAD REAR LANE**

On its western side from its junction with the northern kerblines of Gwydr Crescent for a distance of 13 metres north.

On its western side from its junction with the southern kerblines of Gwydr Crescent for a distance of 10 metres south.

On its eastern side from a point opposite a point 13 metres north of its junction with the northern kerblines of Gwydr Crescent for a distance of 27 metres south.

## **LLYTHRID AVENUE**

On its western side from its junction with the southern kerblines of Pinewood Road for a distance of 15 metres south.

On its western side from its junction with the northern kerblines of Sketty Road for a distance of 10 metres north.

On its eastern side from its junction with the southern kerblines of Pinewood Road for a distance of 10 metres south.

On its eastern side from its junction with the northern kerblines of Long Oaks Avenue for a distance of 10 metres north.

On its eastern side from its junction with the southern kerblines of Long Oaks Avenue for a distance of 10 metres south.

On its eastern side from its junction with the northern kerblines of Sketty Road for a distance of 10 metres north.

## **SKETTY ROAD**

On its northern side from its junction with the eastern kerblines of Llythrid Avenue for a distance of 10 metres west.

On its northern side from its junction with the western kerblines of Llythrid Avenue for a distance of 10 metres east.

## **LONG OAKS AVENUE**

On both sides 10 metres east from the junction of the eastern kerblines of Llythrid Avenue.

### **PINEWOOD ROAD**

On its southern side from its junction with the eastern kerblines of Llythrid Avenue for a distance of 10 metres west.

On its southern side from its junction with the western kerblines of Llythrid Avenue for a distance of 10 metres east.

### **SCHEDULE 3**

### **PERMIT HOLDERS ONLY AT ANY TIME**

### **CAMBRIDGE STREET**

On its southern western side from a point 11 metres north of the north kerblines of Victoria Street north for a distance of 24 metres.

On its southern western side from a point 70 metres north of the north kerblines of Victoria Street north for a distance of 30 metres.

On its southern western side from a point 112 metres north of the north kerblines of Victoria Street north for a distance of 24 metres.

On its northern eastern side from a point 44 metres north of the north kerblines of Victoria Street north for a distance of 30 metres.

On its northern eastern side from a point 93 metres north of the north kerblines of Victoria Street north for a distance of 30 metres.

### **KNOLL AVENUE**

On its western side from a point 33 metres north of the north kerblines of Beechwood Road north for a distance of 24 metres.

### **WINDSOR STREET**

On its southern side from a point 31 metres west of the western kerblines of Glanmor Road west for a distance of 30 metres.

On its northern side from a point 79 metres west of the western kerblines of Glanmor Road west for a distance of 15 metres.

### **BRUNSWICK STREET**

On its northern side from a point 59 metres west of the western kerblines of Duke Street west for a distance of 6 metres.

### **MARLBOROUGH ROAD**

On its northern side from a point 44 metres west of the western kerblines of Rhyddings Park Road west for a distance of 15 metres.

On its northern side from a point 105 metres west of the western kerblines of Rhyddings Park Road west for a distance of 15 metres.

On its western side from a point 86 metres west of the western kerblines of Bernard Street south for a distance of 15 metres.

On its western side from a point 160 metres west of the western kerblines of Bernard Street south for a distance of 15 metres.

On its Southern side from a point 43 metres west of the western kerblines of Bernard Street south for a distance of 15 metres.

### **AYLESBURY ROAD**

On its northern side from a point 32 metres west of its junction with the western kerblines of Bernard Street for a distance of 9 metres west.

On its northern side from a point 63 metres west of its junction with the western kerblines of Bernard Street for a distance of 5 metres west.

On its northern side from a point 79 metres west of its junction with the western kerblines of Bernard Street for a distance of 15 metres west.

On its southern side from a point 53 metres west of its junction with the western kerblines of Bernard Street for a distance of 9 metres west.

On its southern side from a point 84 metres west of its junction with the western kerblines of Bernard Street for a distance of 15 metres west.

### **SCHEDULE 4**

**LIMITED WAITING Mon – Sat 8am – 6pm 1 HOUR NO RETURN WITHIN 2 HOURS PERMIT HOLDERS EXEMPT**

### **LLYTHRID AVENUE**

On its western side from a point 15 metres south of its junction with the southern kerblines of Pinewood Road for a distance of 75 metres south.

### **SCHEDULE 5**

**DISABLED BADGE HOLDERS ONLY AT ANY TIME**

### **BRUNSWICK STREET**

On its northern side from a point 76 metres west of its junction with the western kerblines of Duke Street for a distance of 6 metres west.

### **AYLESBURY ROAD**

On its northern side from a point 27 metres west of its junction with the western kerb line of Bernard Street for a distance of 6 metres west.

### **AYLESBURY ROAD**

On its northern side from a point 68 metres west of its junction with the western kerb line of Bernard Street for a distance of 6 metres west.

### **SCHEDULE 6**

**DISABLED BADGE HOLDERS MON – SAT 8am – 6pm 2 HOURS NO RETURN WITHIN 2 HOURS**

### **GWYDR SQUARE**

On its eastern side from a point 3 metres north of its junction with the northern kerblines of the lane between Gwydr Crescent and Eaton Crescent for a distance of 6 metres north.

### **BEECHWOOD ROAD**

On its northern side from a point 25 metres west of its junction with the western kerblines of Gwydr Square for a distance of 6 metres west.

### **SCHEDULE 7**

#### **ORDERS TO BE REVOKED**

#### **HAWTHORNE AVENUE - No waiting at Any Time (DVT 00250263)**

On its southwestern side from a point 5 metres south east of the south eastern kerblines of Edgeware Road for a distance of 3 metres in a north westerly direction.

#### **HAWTHORNE AVENUE - No waiting at Any Time (DVT 00250263)**

On its northeastern side from a point 4 metres north west of the northern kerblines of Windsor Street for a distance of 3 metres northwest.

#### **GLANBRYDAN AVENUE - No waiting at Any Time (CB84/09 – 1984)**

On its northern side 11 metres east with the eastern kerblines of Bernard Street for a distance of 6 metres east.

#### **GLANBRYDAN AVENUE - No waiting at Any Time (CB84/09 – 1984)**

On its southern side 8 metres west of its junction with the western kerblines of Bernard Street for a distance of 8 metres west.

#### **BERNARD STREET - No waiting at Any Time (CB84/09 – 1984)**

On its western side 9 metres south of its junction of the southern kerblines of Glanbrydan Avenue for a distance of 5 metres south.

**BRYN ROAD - No waiting or No loading at Any time (CB79/03 – 1978)**

On its northern side 23 metres from the junction of the southeastern kerblines of Osborne Terrace for a distance of 24 metres northeast.

30<sup>th</sup> May 2024

**Tracey Meredith**

**Chief Legal Officer / Prif Swyddog Cyfreithiol**

**THE COUNCIL OF THE CITY  
AND COUNTY OF SWANSEA  
CYNGOR DINAS A SIR ABERTAWE**



**PROPOSED TRAFFIC REGULATION  
VARIOUS RESTRICTIONS – UPLANDS WARD  
ORDER 2024**

**DVT- 00274610/AVR**

**THE COUNCIL OF THE CITY  
AND COUNTY OF SWANSEA  
CYNGOR DINAS A SIR ABERTAWE  
VARIOUS RESTRICTIONS – UPLANDS WARD  
ORDER 2024**

**THE COUNCIL OF THE CITY AND COUNTY OF SWANSEA** (hereinafter called “the Council”) in exercise of its powers under Sections the Road Traffic Regulation Act 1984, as amended (hereinafter referred to as “the Act of 1984”) and the Traffic Management Act 2004 and the Local Government (Miscellaneous Provisions) Act 1976 and of all other enabling powers and after consultation with the Chief Officer of Police in accordance with Part III of Schedule 9 and Section 124 of the Act of 1984 hereby make the following Order.

**SECTION 1 – PRELIMINARY**

Citation and commencement

1. This Order shall come into operation on 6<sup>th</sup> June 2024 and may be cited as the Council of the City and County of Swansea, Various Restrictions – Uplands Ward, Order 2024

Definitions

2. In this order, except where the context otherwise requires, the following expressions have the meaning hereby respectively assigned to them:

“Civil Enforcement Officer” has the same meaning as in Section 63A of the Act of 1984 and by virtue of Section 76 of the 2004 Act a Civil Enforcement Officer appointed under Section 63A of the Act of 1984 is a Civil Enforcement Officer in relation to parking contraventions;

“Disabled Person’s Badge” has the same meaning as in the Disabled Persons (Badges for Motor Vehicles)(Wales) Regulation 2000;

“Disabled Person’s Vehicle” has the same meaning as in the Local Authorities’ Traffic Orders (Exemption for Disabled Persons) (Wales) Regulations 2000

“Parking Disc” means a disc issued by a Local Authority complying with the requirements of the British Standard Specifications for Parking Discs to comply with the European Blue Badge Scheme being a disc coloured blue and capable of showing the quarter hour period during which a period of waiting begins;



“Public Service Vehicles” means a vehicle carrying passengers for a fee and for the purposes of this Order Public Service Vehicles refers to a large Public Service Vehicles capable of carrying more than eight passengers;

“Relevant Position” in respect of:-

(a) a Disabled Person’s Badge and Parking Disc has the same meaning as in the Local Authorities’ Traffic Orders (Exemptions for Disabled Persons) (Wales) Regulations 2000;

(b) a permit means exhibited on the windscreen, dashboard or fascia of the vehicle or, where the vehicle does not have a windscreen, dashboard or fascia, in a conspicuous position on the vehicle so that the whole of the information on the front of the permit is clearly legible from outside the vehicle; and

(c) a Waiver means exhibited on the windscreen, dashboard or fascia of the vehicle or, where the vehicle does not have a windscreen, dashboard or fascia, in a conspicuous position on the vehicle so that the whole of the information on the front of the Waiver is clearly legible from outside the vehicle;

"Virtual Parking Permit" means an electronic record of parking ticket, permit or dispensation issued and confirmed by the Council to exempt a vehicle from a restriction or to make payment other than on site covered in the provisions of this order, under the terms applicable at the time of issue. A Virtual Parking Permit may be obtained by any of the methods provided from time to time by the Council and to be valid must be registered on an account in an electronic database approved by the Council with an indication that the permit has been issued and validated in accordance with Council procedures.

“Waiver” means a Waiver issued by the Council in respect of vehicles being used for building maintenance repair shop fitting or other industrial or demolition operations and the Council may charge for such Waiver such charge to be determined from time to time by resolution of the Council or relevant Committee thereof;

### Interpretation

3. Except where otherwise stated, any reference in this Order to a numbered Article or Schedule is a reference to the Article or Schedule bearing that number in this Order

4. The Interpretation Act 1978 shall apply for the interpretation of this Order as it applies for the Interpretation of an Act of Parliament
5. The prohibitions and restrictions imposed by this Order shall be in addition to and not in derogation of any other prohibition or restriction whether made under the Act of 1984 or otherwise

## **SECTION 2 - NO WAITING AT ANY TIME**

6. Save as provided in Articles 7 and 8 no person shall, except upon the direction or with the permission of a Civil Enforcement Officer, police officer in uniform, or a person authorised by the Council, cause or permit any vehicle to wait at any time on the length or lengths of the road or roads referred to in Schedule 2 hereto.

### Exemptions

7. Nothing in Article 6 of this Order shall render it unlawful to cause or permit any vehicle to wait on the side or sides or length or lengths of the road or roads specified therein for as long as may be necessary to enable:-
  - a. the vehicle, if it cannot conveniently be used for such purpose in any other road, to be used in connection with any of the following operations namely:-
    - i. building, maintenance, repair, shop fitting or other industrial or demolition operations with a Waiver issued by the Council and displayed in the Relevant Position on the windscreen of the vehicle;
    - ii. the removal of any obstruction to traffic;
    - iii. the laying, erection, alteration or repair in or on land adjacent to the said lengths or sides of the road of any sewer or any main pipe or apparatus for the supply of water, gas electricity or of any telecommunications apparatus as defined by the Telecommunications Act 1984
    - iv. a vehicle being used for police, Ambulance, fire brigade or other emergency purposes
  - b. the vehicle if it cannot conveniently be used for such purpose in any other road, to be used in connection with the service of a local authority or of a water authority in pursuance of its statutory powers and duties.

- c. the vehicle of the Royal Mail or other universal services provider as defined in Section 27 of the Postal Services Act 2011 to be used for the purpose of delivering or collecting mail.
  - d. Public Service Vehicles when waiting at an authorised Bus stop to set down or pick up passengers
  - e. vehicles picking up and dropping off passengers
8. Nothing in Article 6 of this Order shall render it unlawful to cause or permit a disabled person's vehicle which displays in the Relevant Position a Disabled Persons Badge and a Parking Disc (on which the driver, or other person in charge of the vehicle, has marked the time at which the period of waiting began) to wait on lengths of sides of roads referred to in the Article for a period not exceeding 3 hours (not being a period separated by an interval of less than 1 hour from the previous period of waiting by the same vehicle on the same length of side of road on which that vehicle had previously been waiting).

### **SECTION 3 – PERMIT HOLDERS ONLY**

9. Save as provided in Articles 11 and 12 no person shall, except upon the direction or with the permission of a Civil Enforcement Officer, police officer in uniform, or a person authorised by the Council, cause or permit any vehicle to stop at any time on any of the length or lengths of the road or roads referred to in Schedule 3 hereto.
10. Where Article 9 applies no person shall, except upon the direction or with the permission of a Civil Enforcement Officer, police officer in uniform, or a person authorised by the Council, cause or permit any vehicle displaying a Disabled Person's Badge to wait within a designated permit only parking bay.

#### Exemptions

11. Nothing in Article 9 of this Order shall render it unlawful to cause or permit a vehicle displaying a physical permit in the Relevant Position or subject to a Virtual Parking Permit covering the specified area to stop on the side or sides or length or lengths of the road or roads specified in Schedule 3.
12. Nothing in Article 9 of this Order shall render it unlawful to cause or permit any vehicle to stop on the side or sides or length or lengths of the road or roads specified therein for as long as may be necessary to enable:-

- (a) the vehicle, if it cannot conveniently be used for such purpose in any other road, to be used in connection with any of the following operations namely:-
  - (i) building, maintenance, repair, shop fitting or other industrial or demolition operations with a Waiver issued by the Council and displayed in the Relevant Position on the windscreen of the vehicle;
  - (ii) the removal of any obstruction to traffic;
  - (iii) the laying, erection, alteration or repair in or on land adjacent to the said lengths or sides of the road of any sewer or any main pipe or apparatus for the supply of water, gas electricity or of any telecommunications apparatus as defined by the Telecommunications Act 1984
  - (iv) a vehicle being used for police, Ambulance, fire brigade or other emergency purposes
- (b) the vehicle if it cannot conveniently be used for such purpose in any other road, to be used in connection with the service of a local authority or of a water authority in pursuance of its statutory powers and duties.
- (c) the vehicle of the Royal Mail or other universal services provider as defined in Section 27 of the Postal Services Act 2011 to be used for the purpose of delivering or collecting mail.
- (d) Public Service Vehicles when waiting at an authorised Bus stop to set down or pick up passengers
- (e) vehicles picking up and dropping off passengers

**SECTION 4 – LIMITED WAITING 1 HOUR NO RETURN WITHIN 2 HOURS MONDAY - SATURDAY 8AM – 6PM RESIDENT PERMIT HOLDERS EXEMPT**

13. Save as provided in Articles 16, 17 and 18 no person shall, except upon the direction or with the permission of a Civil Enforcement Officer, police officer in uniform, or a person authorised by the Council, cause or permit any vehicle to wait between 8 AM and 6PM Monday to Saturday for a period of time in excess 1 hour separated by a period of 2 hours on any of the length or lengths of the road or roads referred to in Schedule 4 hereto.

14. Save as provided in Articles 16 and 17 no person shall, except upon the direction or with the permission of a Civil Enforcement Officer, police officer in uniform, or a person authorised by the Council, cause or permit any vehicle to wait between 6PM and 8AM Monday to Saturday on any of the length or lengths of the road or roads referred to in Schedule 4 hereto.
15. Where Article 14 applies no person shall, except upon the direction or with the permission of a Civil Enforcement Officer, police officer in uniform, or a person authorised by the Council, cause or permit any vehicle displaying a Disabled Person's Badge within a designated permit only parking bay.

### Exemptions

16. Nothing in Article 13 and 14 of this Order shall render it unlawful to cause or permit a vehicle displaying a physical permit in the Relevant Position or subject to a Virtual Parking Permit covering the specified area to wait on the side or sides or length or lengths of the road or roads specified in Schedule 4.
17. Nothing in Article 13 and 14 of this Order shall render it unlawful to cause or permit any vehicle to wait on the side or sides or length or lengths of the road or roads specified therein for as long as may be necessary to enable:-
- (a) the vehicle, if it cannot conveniently be used for such purpose in any other road, to be used in connection with any of the following operations namely:-
    - (i) building, maintenance, repair, shop fitting or other industrial or demolition operations with a Waiver issued by the Council and displayed in the Relevant Position on the windscreen of the vehicle;
    - (ii) the removal of any obstruction to traffic;
    - (iii) the laying, erection, alteration or repair in or on land adjacent to the said lengths or sides of the road of any sewer or any main pipe or apparatus for the supply of water, gas electricity or of any telecommunications apparatus as defined by the Telecommunications Act 1984
    - (iv) a vehicle being used for police, Ambulance, fire brigade or other emergency purposes
  - (b) the vehicle if it cannot conveniently be used for such purpose in any other road, to be used in connection with the service of a local authority or of a water authority in pursuance of its statutory powers and duties.

(c) the vehicle of the Royal Mail or other universal services provider as defined in Section 27 of the Postal Services Act 2011 to be used for the purpose of delivering or collecting mail.

(d) Public Service Vehicles when waiting at an authorised Bus stop to set down or pick up passengers

(e) vehicles picking up and dropping off passengers

18. Nothing in Article 13 of this Order shall render it unlawful to cause or permit a disabled person's vehicle which displays in the Relevant Position a Disabled Persons Badge and a Parking Disc (on which the driver, or other person in charge of the vehicle, has marked the time at which the period of waiting began) to wait on lengths of sides of roads referred to in the Article for a period not exceeding 3 hours (not being a period separated by an interval of less than 1 hour from the previous period of waiting by the same vehicle between in the hours of 8AM – 6PM on Monday to Saturday inclusive, on the same length of side of road on which that vehicle had previously been waiting.

## **SECTION 5 – DISABLED PERSONS' PARKING PLACES**

19. Save as provided in Articles 20 and 21 no person shall, except upon the direction or with the permission of a Civil Enforcement Officer, police officer in uniform, or a person authorised by the Council, cause or permit any vehicle to stop at any time on any of the length or lengths of the road or roads referred to in Schedule 5 hereto.

### Exemptions

20. Nothing in Article 19 of this Order shall render it unlawful to cause or permit a vehicle displaying a Disabled Persons Badge in the Relevant Position to stop on the side or sides or length or lengths of the road or roads specified in Schedule 5.

21. Nothing in Article 19 of this Order shall render it unlawful to cause or permit any vehicle to stop on the side or sides or length or lengths of the road or roads specified therein for as long as may be necessary to enable:-

(a) the vehicle, if it cannot conveniently be used for such purpose in any other road, to be used in connection with any of the following operations namely:-

(i) building, maintenance, repair, shop fitting or other industrial or demolition operations with a Waiver issued by the Council and displayed in the Relevant Position on the windscreen of the vehicle;

- (ii) the removal of any obstruction to traffic;
- (iii) the laying, erection, alteration or repair in or on land adjacent to the said lengths or sides of the road of any sewer or any main pipe or apparatus for the supply of water, gas electricity or of any telecommunications apparatus as defined by the Telecommunications Act 1984
- (iv) a vehicle being used for police, Ambulance, fire brigade or other emergency purposes
- (b) the vehicle if it cannot conveniently be used for such purpose in any other road, to be used in connection with the service of a local authority or of a water authority in pursuance of its statutory powers and duties.
- (c) the vehicle of the Royal Mail or other universal services provider as defined in Section 27 of the Postal Services Act 2011 to be used for the purpose of delivering or collecting mail.
- (d) Public Service Vehicles when waiting at an authorised Bus stop to set down or pick up passengers
- (e) vehicles picking up and dropping off passengers

**SECTION 6 - DISABLED BADGE HOLDERS MONDAY – SATURDAY 8AM – 6PM 2 HOURS NO RETURN WITHIN 2 HOURS**

22. Save as provided in Articles 23 and 24 no person shall, except upon the direction or with the permission of a Civil Enforcement Officer, police officer in uniform, or a person authorised by the Council, cause or permit any vehicle to wait between the hours of 8AM -6PM Monday to Saturday inclusive along any of the length or lengths of the road or roads referred to in Schedule 6 hereto.

Exemptions

23. Nothing in Article 22 of this Order shall render it unlawful to cause or permit a vehicle displaying a Disabled Persons Badge and a Parking Disc (on which the driver, or other person in charge of the vehicle, has marked the time at which the period of waiting began) in the Relevant Position to park between 8 AM and 6PM Monday to Saturday for a period of time in excess 2 hour separated by a period of 2 hours on the side or sides or length or lengths of the road or roads specified in Schedule 6.

24. Nothing in Article 22 of this Order shall render it unlawful to cause or permit any vehicle to stop on the side or sides or length or lengths of the road or roads specified therein for as long as may be necessary to enable:-

- (a) the vehicle, if it cannot conveniently be used for such purpose in any other road, to be used in connection with any of the following operations namely:-
  - (i) building, maintenance, repair, shop fitting or other industrial or demolition operations with a Waiver issued by the Council and displayed in the Relevant Position on the windscreen of the vehicle;
  - (ii) the removal of any obstruction to traffic;
  - (iii) the laying, erection, alteration or repair in or on land adjacent to the said lengths or sides of the road of any sewer or any main pipe or apparatus for the supply of water, gas electricity or of any telecommunications apparatus as defined by the Telecommunications Act 1984
  - (iv) a vehicle being used for police, Ambulance, fire brigade or other emergency purposes
- (b) the vehicle if it cannot conveniently be used for such purpose in any other road, to be used in connection with the service of a local authority or of a water authority in pursuance of its statutory powers and duties.
- (c) the vehicle of the Royal Mail or other universal services provider as defined in Section 27 of the Postal Services Act 2011 to be used for the purpose of delivering or collecting mail.
- (d) Public Service Vehicles when waiting at an authorised Bus stop to set down or pick up passengers
- (e) vehicles picking up and dropping off passengers

## **SECTION 7 - REVOCATIONS**

25. The existing Orders are revoked insofar as they are inconsistent with the proposals contained in the schedules hereto and insofar as they relate to the length or lengths of the road or roads as referred to in Schedules 1 hereto and those specified in Schedule 7 insofar as they relate to the following Orders:



- “The Council of the City and County of Swansea, Uplands Phase 2 TRO 2020 Swansea Order 2020”
- “West Glamorgan County Council (Bernard Street/Glanbrydan Avenue Junction, Swansea) (Prohibition of Waiting) Order 1984”
- “The West Glamorgan County Council (Bryn Road and King Edward Road Area Swansea) (Revocation and Prohibition of Waiting) Order 1978”

## **SCHEDULES**

### **SCHEDULE 1**

#### **REVOCATIONS**

The existing Orders are revoked as far as they are inconsistent with the proposals hereinafter contained which relate to the length or lengths of the road or roads referred to in the schedules hereto.

### **SCHEDULE 2**

#### **PROHIBITION OF WAITING AT ANY TIME**

##### **HAWTHORNE AVENUE**

On its southern side from its junction with the northern kerblines of Hazel Road west ward for a distance of 6 metres.

##### **HAZEL ROAD**

On its northern side from its junction with the southern kerblines of Hawthorne Avenue west ward for a distance of 6 metres.

##### **HAWTHORNE AVENUE**

On its southwestern side from its junction with the northern kerblines of Pinewood Road northwest for a distance of 6 metres.

##### **PINEWOOD ROAD**

On its northern side from its junction with the southwestern kerblines of Hawthorne Avenue west for a distance of 6 metres.

##### **BERNARD STREET**

On both sides, from its junction with the northern kerblines of Glanbrydan Avenue for a distance of 10 metres north.

##### **GWYDR CRESCENT**

On its southern side from its junction with eastern kerblines of Rhyddings Park Road to its junction with the western kerblines of Rhyddings Park Road rear lane, a distance of 29 metres.

On its northern side from its junction with the western kerblines of Rhyddings Park Road rear lane for a distance of 3 metres west.

##### **RHYDDINGS PARK ROAD REAR LANE**

On its western side from its junction with the northern kerblines of Gwydr Crescent for a distance of 13 metres north.

On its western side from its junction with the southern kerblines of Gwydr Crescent for a distance of 10 metres south.

On its eastern side from a point opposite a point 13 metres north of its junction with the northern kerblines of Gwydr Crescent for a distance of 27 metres south.

### **LLYTHRID AVENUE**

On its western side from its junction with the southern kerblines of Pinewood Road for a distance of 15 metres south.

On its western side from its junction with the northern kerblines of Sketty Road for a distance of 10 metres north.

On its eastern side from its junction with the southern kerblines of Pinewood Road for a distance of 10 metres south.

On its eastern side from its junction with the northern kerblines of Long Oaks Avenue for a distance of 10 metres north.

On its eastern side from its junction with the southern kerblines of Long Oaks Avenue for a distance of 10 metres south.

On its eastern side from its junction with the northern kerblines of Sketty Road for a distance of 10 metres north.

### **SKETTY ROAD**

On its northern side from its junction with the eastern kerblines of Llythrid Avenue for a distance of 10 metres west.

On its northern side from its junction with the western kerblines of Llythrid Avenue for a distance of 10 metres east.

### **LONG OAKS AVENUE**

On both sides 10 metres east from the junction of the eastern kerblines of Llythrid Avenue.

### **PINEWOOD ROAD**

On its southern side from its junction with the eastern kerblines of Llythrid Avenue for a distance of 10 metres west.

On its southern side from its junction with the western kerblines of Llythrid Avenue for a distance of 10 metres east.

## **SCHEDULE 3**

### **PERMIT HOLDERS ONLY AT ANY TIME**

#### **CAMBRIDGE STREET**

On its southern western side from a point 11 metres north of the north kerbline of Victoria Street north for a distance of 24 metres.

On its southern western side from a point 70 metres north of the north kerbline of Victoria Street north for a distance of 30 metres.

On its southern western side from a point 112 metres north of the north kerbline of Victoria Street north for a distance of 24 metres.

On its northern eastern side from a point 44 metres north of the north kerbline of Victoria Street north for a distance of 30 metres.

On its northern eastern side from a point 93 metres north of the north kerbline of Victoria Street north for a distance of 30 metres.

#### **KNOLL AVENUE**

On its western side from a point 33 metres north of the north kerbline of Beechwood Road north for a distance of 24 metres.

#### **WINDSOR STREET**

On its southern side from a point 31 metres west of the western kerbline of Glanmor Road west for a distance of 30 metres.

On its northern side from a point 79 metres west of the western kerbline of Glanmor Road west for a distance of 15 metres.

#### **BRUNSWICK STREET**

On its northern side from a point 59 metres west of the western kerbline of Duke Street west for a distance of 6 metres.

#### **MARLBOROUGH ROAD**

On its northern side from a point 44 metres west of the western kerbline of Rhyddings Park Road west for a distance of 15 metres.

On its northern side from a point 105 metres west of the western kerbline of Rhyddings Park Road west for a distance of 15 metres.

On its western side from a point 86 metres west of the western kerbline of Bernard Street south for a distance of 15 metres.

On its western side from a point 160 metres west of the western kerbline of Bernard Street south for a distance of 15 metres.

On its Southern side from a point 43 metres west of the western kerbline of Bernard Street south for a distance of 15 metres.

#### **AYLESBURY ROAD**

On its northern side from a point 32 metres west of its junction with the western kerb line of Bernard Street for a distance of 9 metres west.

On its northern side from a point 63 metres west of its junction with the western kerb line of Bernard Street for a distance of 5 metres west.

On its northern side from a point 79 metres west of its junction with the western kerb line of Bernard Street for a distance of 15 metres west.

On its southern side from a point 53 metres west of its junction with the western kerb line of Bernard Street for a distance of 9 metres west.

On its southern side from a point 84 metres west of its junction with the western kerb line of Bernard Street for a distance of 15 metres west.

#### **SCHEDULE 4**

**LIMITED WAITING Mon – Sat 8am – 6pm 1 HOUR NO RETURN WITHIN 2 HOURS PERMIT HOLDERS EXEMPT**

#### **LLYTHRID AVENUE**

On its western side from a point 15 metres south of its junction with the southern kerb line of Pinewood Road for a distance of 75 metres south.

#### **SCHEDULE 5**

**DISABLED BADGE HOLDERS ONLY AT ANY TIME**

#### **BRUNSWICK STREET**

On its northern side from a point 76 metres west of its junction with the western kerb line of Duke Street for a distance of 6 metres west.

#### **AYLESBURY ROAD**

On its northern side from a point 27 metres west of its junction with the western kerb line of Bernard Street for a distance of 6 metres west.

#### **AYLESBURY ROAD**

On its northern side from a point 68 metres west of its junction with the western kerb line of Bernard Street for a distance of 6 metres west.

## **SCHEDULE 6**

### **DISABLED BADGE HOLDERS MON – SAT 8am – 6pm 2 HOURS NO RETURN WITHIN 2 HOURS**

#### **GWYDR SQUARE**

On its eastern side from a point 3 metres north of its junction with the northern kerbline of the lane between Gwydr Crescent and Eaton Crescent for a distance of 6 metres north.

#### **BEECHWOOD ROAD**

On its northern side from a point 25 metres west of its junction with the western kerbline Gwydr Square for a distance of 6 metres west.

## **SCHEDULE 7**

### **ORDERS TO BE REVOKED**

#### **HAWTHORNE AVENUE - No waiting at Any Time (DVT 00250263)**

On its southwestern side from a point 5 metres south east of the south eastern kerbline of Edgeware Road for a distance of 3 metres in a north westerly direction.

#### **HAWTHORNE AVENUE - No waiting at Any Time (DVT 00250263)**

On its northeastern side from a point 4 metres north west of the northern kerbline of Windsor Street for a distance of 3 metres northwest.

#### **GLANBRYDAN AVENUE - No waiting at Any Time (CB84/09 – 1984)**

On its northern side 11 metres east with the eastern kerbline of Bernard Street for a distance of 6 metres east.

#### **GLANBRYDAN AVENUE - No waiting at Any Time (CB84/09 – 1984)**

On its southern side 8 metres west of its junction with the western kerbline of Bernard Street for a distance of 8 metres west.

#### **BERNARD STREET - No waiting at Any Time (CB84/09 – 1984)**

On its western side 9 metres south of its junction of the southern kerbline of Glanbrydan Avenue for a distance of 5 metres south.

#### **BRYN ROAD - No waiting or No loading at Any time (CB79/03 – 1978)**

On its northern side 23 metres from the junction of the southeastern kerbline of Osborne Terrace for a distance of 24 metres northeast.

Dated this 24th May 2024

**THE COMMON SEAL OF THE** )  
**COUNCIL OF THE CITY AND** )  
**COUNTY OF SWANSEA** )  
was hereunto affixed )  
in the presence of )

DocuSigned by:  
  
115,543

DocuSigned by:  
*Frederick Jonathan Wills*  
54E315F96B5C44E...  
Authorised Signatory

**STATEMENT OF REASONS**

**Notice of Intent for the Traffic Regulation Order**

**Uplands Ward  
Community Budgets**

The provision of :

- A) avoiding danger to persons or other traffic using the road or any other road or for preventing the likelihood of any such danger arising, or
- B) preventing the likelihood of any such danger arising
- C) for facilitating the passage of vehicular traffic on the road



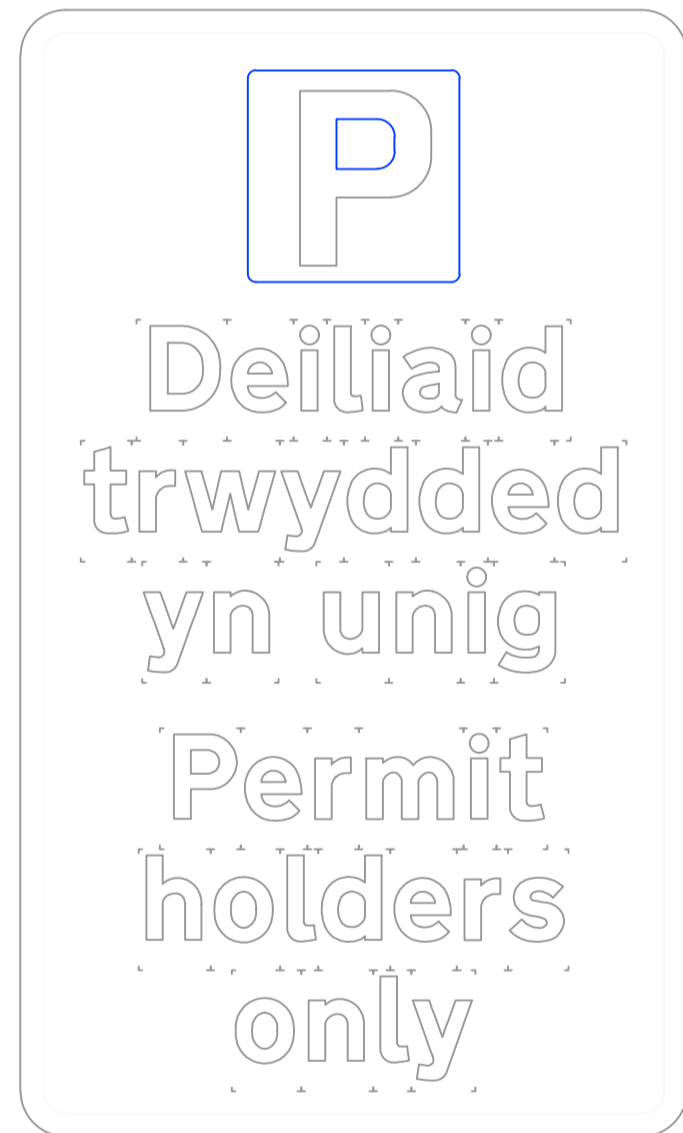
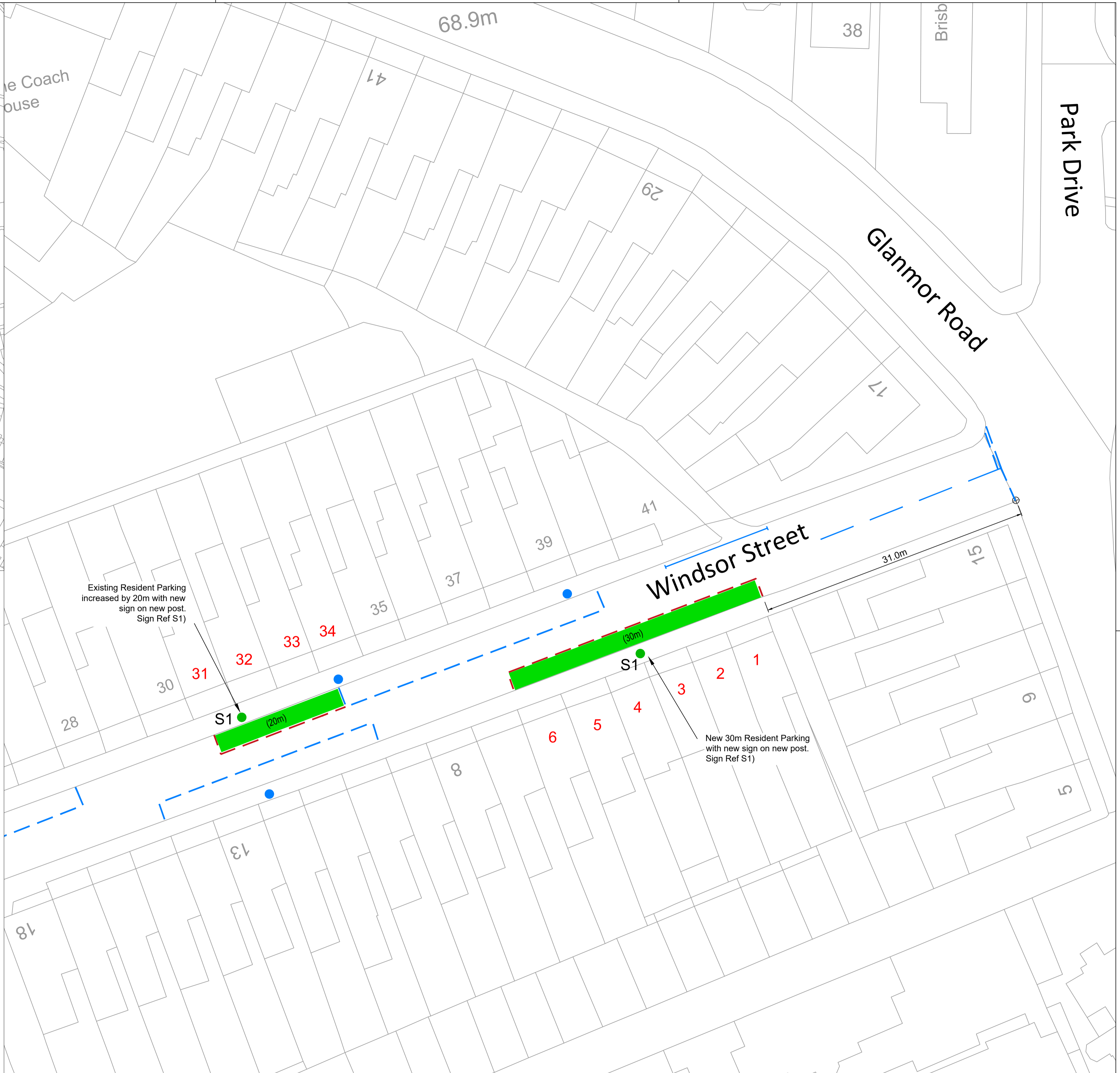
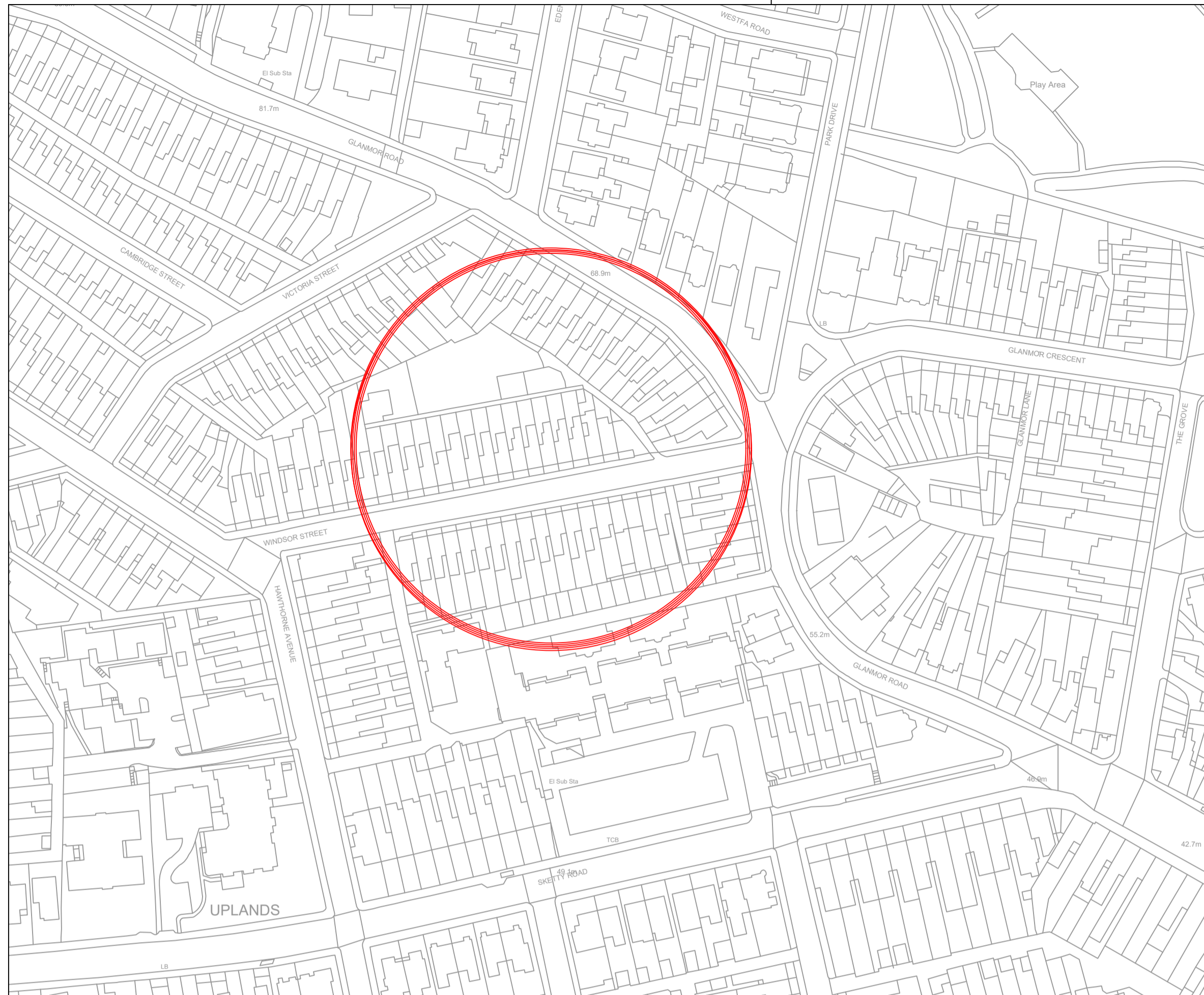

Signing Project	Permit Holders Only - S1				
Sign Reference	TSRGD 660	Width (mm)	220	Background	White
x Height	20.0	Height (mm)	375	Border	Black
Material	Class RA2	Area (m <sup>2</sup> )	0.08	Legend	Black

**NOTES**

- THIS IS A CAD DRAWING AND SHOULD NOT BE AMENDED BY HAND.
- All dimensions in millimetres unless otherwise stated.
- ©Hawffraint y Goron a hawliau cronfa ddata 2023 Yr Arolwg Ordnans 100023509.  
©Crown Copyright and database rights 2023 Ordnance Survey 100023509.
- Any errors or omissions to be reported to the Designer.
- All existing Road Markings are to be made good where affected.

**Key**

- Proposed Traffic Regulation Order Permit Holders/Limited Time 1hr Parking (+ length)
- S1 Location of New Road Sign S1 on New Post
- Existing Road Markings

<b>A1</b>		<b>RHAGARWEINIOL - PRELIMINARY</b>	
Dylunwyd Drawn	AJD	Title	
Archwiliwyd Checked	JD	Community Budget 2023/24 Uplands Ward	
Cymerachwyd Approved	ARJ	Proposed Traffic Regulation Order	
Dyddiad Date	June '23	Windsor Street, Uplands Swansea	
Graddfa Scale	NTS	General Arrangement	
		<b>CYFARWYDDIAETH LLEOEDD DIRECTORATE OF PLACE</b> <small>STUART DAVIES B.Eng., C.Eng., M.I.C.E., MBA, PENNAETH PRIFYRD A CHLUDIANT HEAD OF HIGHWAYS &amp; TRANSPORTATION</small>	
		Rhif y Dyluniad Drawing No	T.23.CB.29.005-01
			-

Rev	Date	Details	Dr	Ch	Ap



**P** Llun - Sad  
 Mon - Sat  
 8 am - 6 pm

Deiliaid trwydded  
 neu  
 1 awr  
 Dim dychwelyd  
 o fewn 2 awr

Permit holders  
 or  
 1 hour  
 No return  
 within 2 hours

**P** Llun - Sad  
 Mon - Sat  
 8 am - 6 pm

Deiliaid trwydded  
 neu  
 1 awr  
 Dim dychwelyd  
 o fewn 2 awr

Permit holders  
 or  
 1 hour  
 No return  
 within 2 hours

Signing Project	Llythrid Avenue	Width (mm)	375	Background	White
Sign Reference	S1	Height (mm)	705	Border	Black
x Height	20.0	Area (m <sup>2</sup> )	0.26	Legend	Black
Material	Class R3B				

**NOTES**

- THIS IS A CAD DRAWING AND SHOULD NOT BE AMENDED BY HAND.
- All dimensions in millimetres unless otherwise stated.
- ©Hawffraint y Goron a hawliau cronfa ddata 2023 Yr Arolwg Ordnans 100023509.  
 ©Crown Copyright and database rights 2023 Ordnance Survey 100023509.
- Any errors or omissions to be reported to the Designer.
- All existing Road Markings are to be made good where affected.

**Key**

- Proposed Traffic Regulation Order Permit Holders/Limited Time 1hr Parking (+ length)
- S1 Location of New Road Sign S1 on New Post
- Proposed Prohibition of Waiting At Any Time Traffic Regulation Order (Double Yellow Lines)

<b>A1</b>		<b>RHAGARWEINIOL - PRELIMINARY</b>	
Dylunwyd Drawn	AJD	Trail Title	
Archwiliwyd Checked	JD	Community Budget 2023/24 Uplands Ward	
Cymerachwyd Approved	ARJ	Proposed Traffic Regulation Order	
Dyddiad Date	June '23	Llythrid Avenue, Uplands Swansea	
Graddfa Scale	NTS	General Arrangement	
		<b>CYFARWYDDIAETH LLEOEDD DIRECTORATE OF PLACE</b> <small>STUART DAVIES B.Eng., C.Eng., M.I.C.E., MBA, PENNAETH PRIFYRD A CHLUDANT HEAD OF HIGHWAYS &amp; TRANSPORTATION</small>	
		Rhif y Dyluniad Drawing No	T.23.CB.29.006-01
			-

Rev	Date	Details	Dr	Ch	Ap

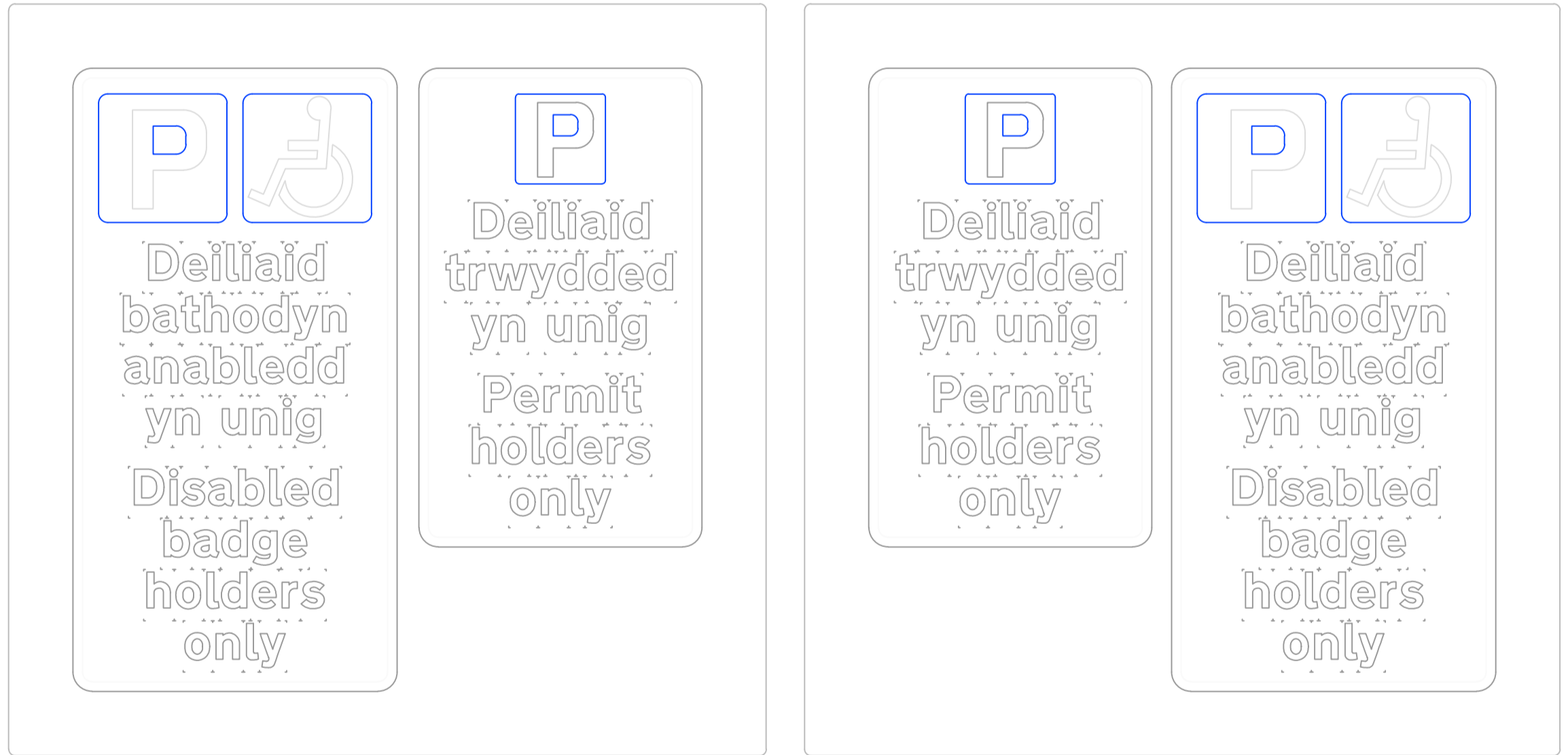
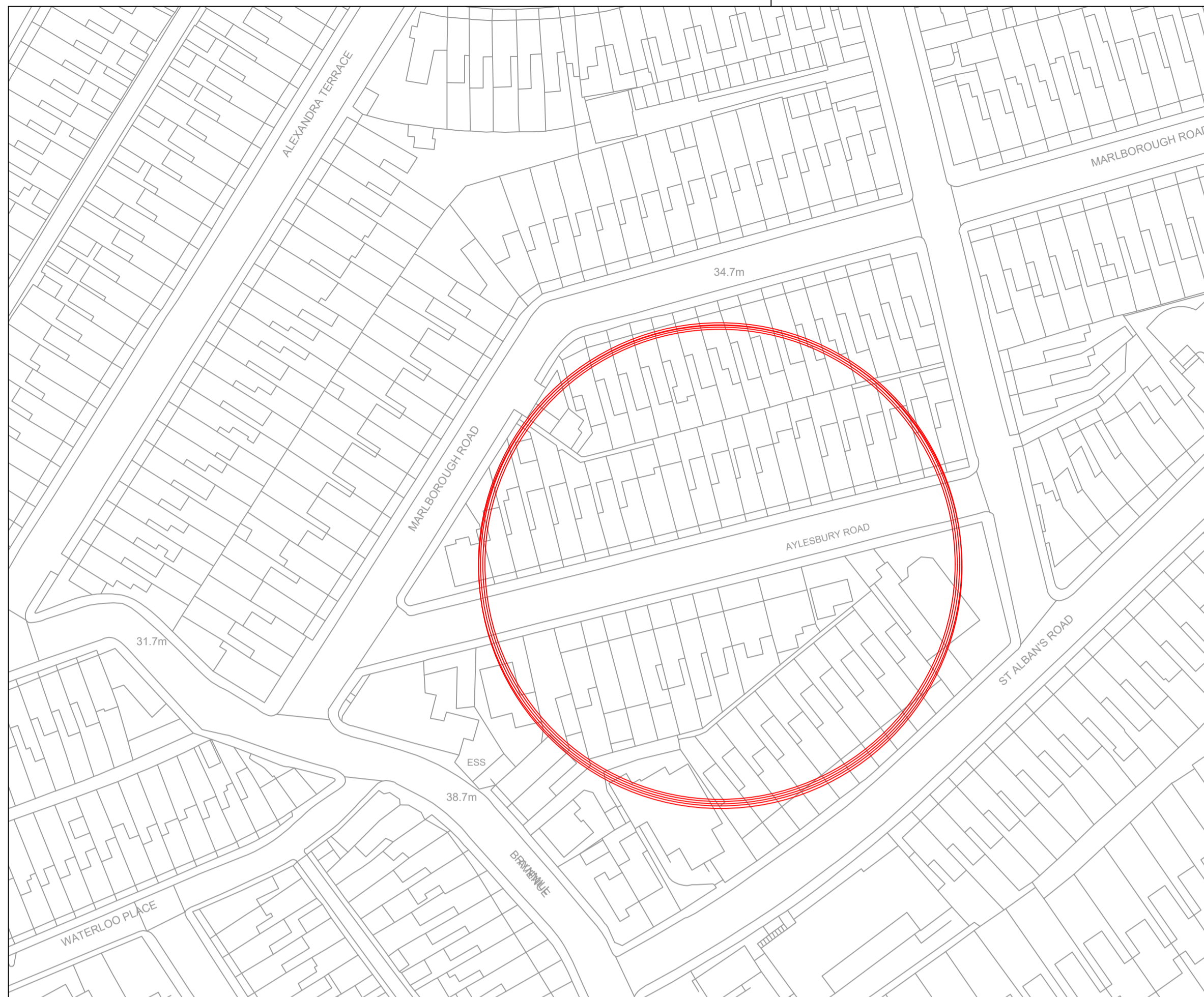

Sign S3a

Sign S3b

Signing Project	Disabled Parking Sign S3a & S3b				
Sign Reference	20.0	Width (mm)	590	Background	Grey
x Height		Height (mm)	585	Border	
Material	Class R3B	Area (m <sup>2</sup> )	0.35	Legend	

**Sign Ref S3a & S3b**  
(1No. of each Sign Required)

**NOTES**

- THIS IS A CAD DRAWING AND SHOULD NOT BE AMENDED BY HAND.
- All dimensions in millimetres unless otherwise stated.
- ©Hawfrait y Goron a hawliau cronfa ddata 2023 Yr Arolwg Ordnans 100023509.  
©Crown Copyright and database rights 2023 Ordnance Survey 100023509.
- Any errors or omissions to be reported to the Designer.
- All existing Road Markings are to be made good where affected.

- KEY**
- S1 ● Proposed Sign on new post
  - Existing Road Markings to remain
  - Existing Traffic Sign
  - Proposed Traffic Regulation Order Permit Holders/Limited Time 1hr Parking (+ length)
  - New Disabled Parking Bay
  - ANABL DISABLED New Text to be added to Bay outside No. 20 & 28
  - DEILIAID TRWYDDEDAU YN UNIG PERMIT HOLDERS ONLY New Text to be added across RP Bays

Rev	Date	Details	Dr	Ch	Ap

<b>A1</b>		<b>RHAGARWEINIOL - PRELIMINARY</b>	
Dylunwyd Drawn	AJD	Trail Title	
Archwiliwyd Checked	JD	Community Budget 2023/24 Uplands Ward	
Cymerachwywyd Approved	ARJ	Proposed Traffic Regulation Order	
Dyddiad Date	June '23	Aylesbury Road, Uplands Swansea	
Graddfa Scale	NTS	General Arrangement	
Cyngor Abertawe Swansea Council		CYFARWYDDIAETH LLEOEDD DIRECTORATE OF PLACE	
Stuart Davies B.Eng., C.Eng., M.I.C.E., MBA, PENNAETH PRIFYRD A CHLUDANT HEAD OF HIGHWAYS & TRANSPORTATION		Rhif y Dyluniad Drawing No	
		T.23.CB.29.007-01	

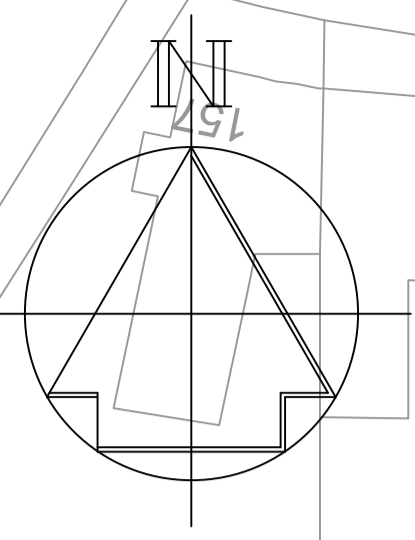

**NOTES**

1. THIS IS A CAD DRAWING AND SHOULD NOT BE AMENDED BY HAND.
2. All dimensions in millimetres unless otherwise stated.
3. ©Hawffraint y Goron a hawliau cronfa ddata 2023 Yr Arolwg Ordnans 100023509.  
©Crown Copyright and database rights 2023 Ordnance Survey 100023509.
4. Any errors or omissions to be reported to the Designer.
5. All existing Road Markings are to be made good where affected.

Rev	Date	Details	Dr	Ch	Ap

**Key**

- Proposed Traffic Regulation Order Permit Holder Only Parking (+ length)
- Location of Existing Road Sign S1 and Post
- Existing Road Markings

<b>A1</b>		<b>RHAGARWEINIOL - PRELIMINARY</b>	
Dylunwyd Drawn	AJD	Tittl Title	Community Budget 2023/24 Uplands Ward
Archwiliwyd Checked	JD		Proposed Traffic Regulation Order
Cymerachwyd Approved	ARJ		Marlborough Road, Uplands Swansea
Dyddiad Date	June '23		General Arrangement
Graddfa Scale	NTS		

**Cyngor Abertawe  
Swansea Council**

**CYFARWYDDIAETH LLEOEDD  
DIRECTORATE OF PLACE**

STUART DAVIES B.Eng., C.Eng., M.I.C.E., MBA,  
PENNAETH PRIFYRDOD A CHLUDANT  
HEAD OF HIGHWAYS & TRANSPORTATION

Rhif y Dyluniad Drawing No

**T.23.CB.29.008-01**

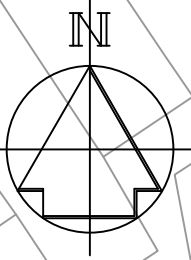
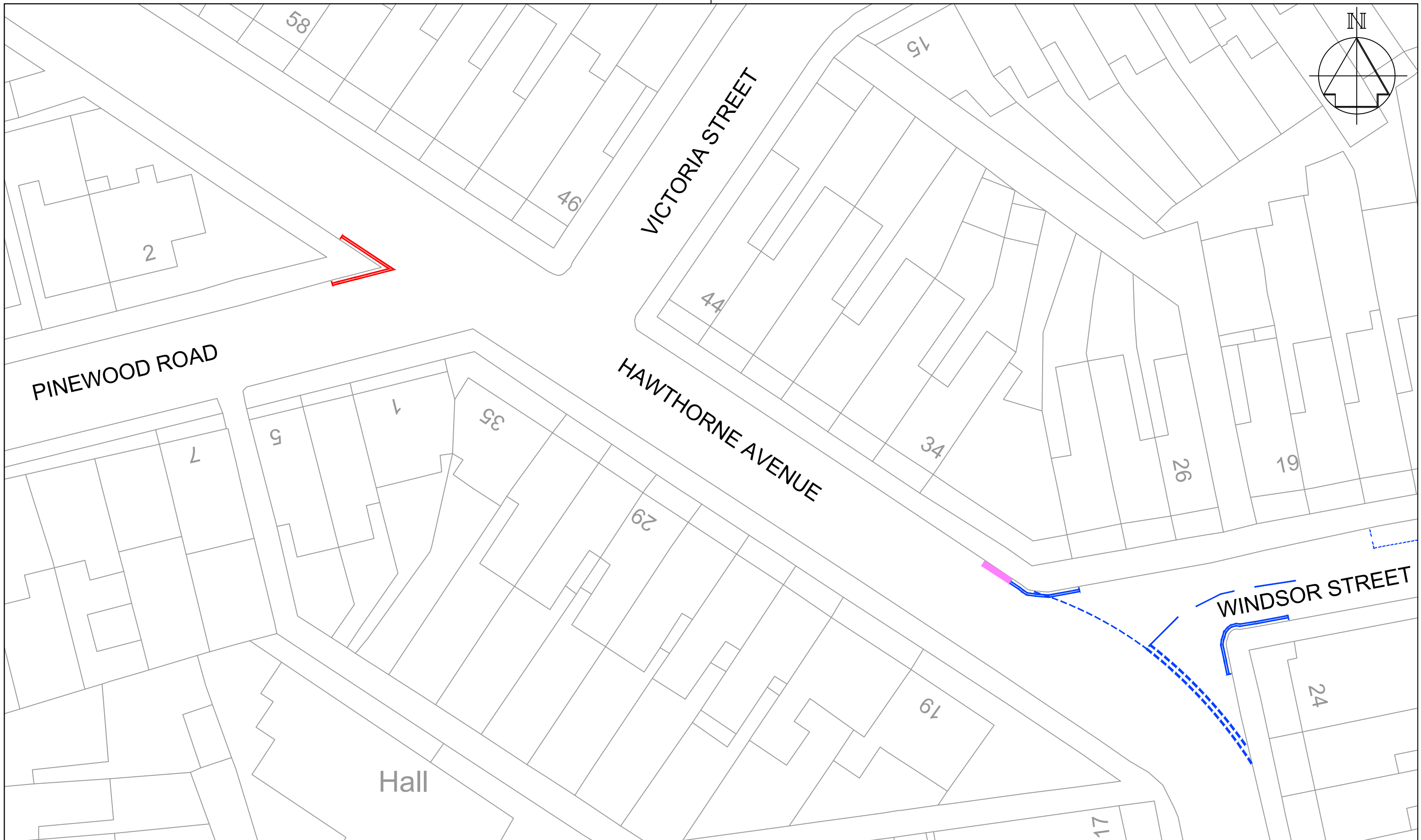

**NOTES**

1. THIS IS A CAD DRAWING AND SHOULD NOT BE AMENDED BY HAND.
2. All dimensions in millimeters unless otherwise stated.
3. ©Hawlfraint y Goron a hawliau cronfa ddata 2022 Yr Arolwg Ordnans 100023509.  
©Crown Copyright and database rights 2022 Ordnance Survey 100023509.
4. Any errors or omissions to be reported to the Designer.

- █ Existing Traffic Regulation Orders
- █ Proposed Prohibition of Waiting At Any Time.
- █ Proposed Revocation of existing Traffic Regulation Order

Rev	Date	Details	Dr	Ch	Ap

<b>A3</b>		<b>RHAGARWEINIOL - PRELIMINARY</b>	
Dyluniwyd Drawn	JD	Title Community Budgets 2022/23 Uplands Area Proposed Traffic Regulation Orders	 <b>CYFARWYDDIAETH LLEOEDD</b> <b>DIRECTORATE OF PLACE</b> <small>STUART DAVIES B.Eng., C.Eng., M.I.C.E., MBA.</small> <small>PENNAETH PRIFYRD A CHILIDYANT</small> <small>HEAD OF HIGHWAYS &amp; TRANSPORTATION</small>
Archwiliwyd Checked	AJ		
Cymeradwywyd Approved	AF	Hawthorne Avenue & Pinewood Road	Rhif y Dyluniad Drawing No
Dyddiad Date	Sep'22		T.22.CB.35.002.04
Graddfa Scale	NTS		

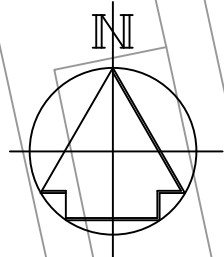

**NOTES**

1. THIS IS A CAD DRAWING AND SHOULD NOT BE AMENDED BY HAND.
2. All dimensions in millimeters unless otherwise stated.
3. ©Hawlfraint y Goron a hawliau cronfa ddata 2022 Yr Arolwg Ordnans 100023509.  
©Crown Copyright and database rights 2022 Ordnance Survey 100023509.
4. Any errors or omissions to be reported to the Designer.

- █ Existing Traffic Regulation Orders
- █ Proposed Prohibition of Waiting At Any Time.
- █ Proposed Revocation of existing Traffic Regulation Order
- █ Proposed Road Markings

Rev	Date	Details	Dr	Ch	Ap

<b>A3</b>		<b>RHAGARWEINIOL - PRELIMINARY</b>	
Dyluniwyd Drawn	JD	Community Budgets 2022/23 Uplands Area Proposed Traffic Regulation Orders	 <b>CYFARWYDDIAETH LLEOEDD</b> <b>DIRECTORATE OF PLACE</b> <small>STUART DAVIES B.Eng., C.Eng., M.I.C.E., MBA.</small> <small>PENNAETH PRIFYRDIO A CHILIDANT</small> <small>HEAD OF HIGHWAYS &amp; TRANSPORTATION</small>
Archwiliwyd Checked	AJ		
Cymeradwywyd Approved	AF	Bernard Street Junction Glanbrydan Avenue	
Dyddiad Date	Sep'22	Rhif y Dyluniad Drawing No	T.22.CB.35.002.05
Graddfa Scale	NTS		

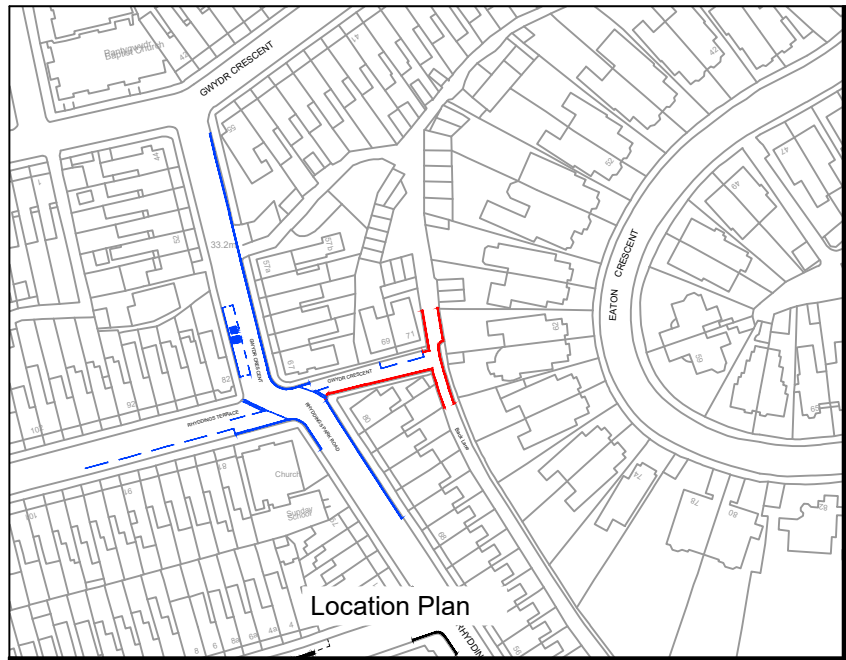

Location Plan

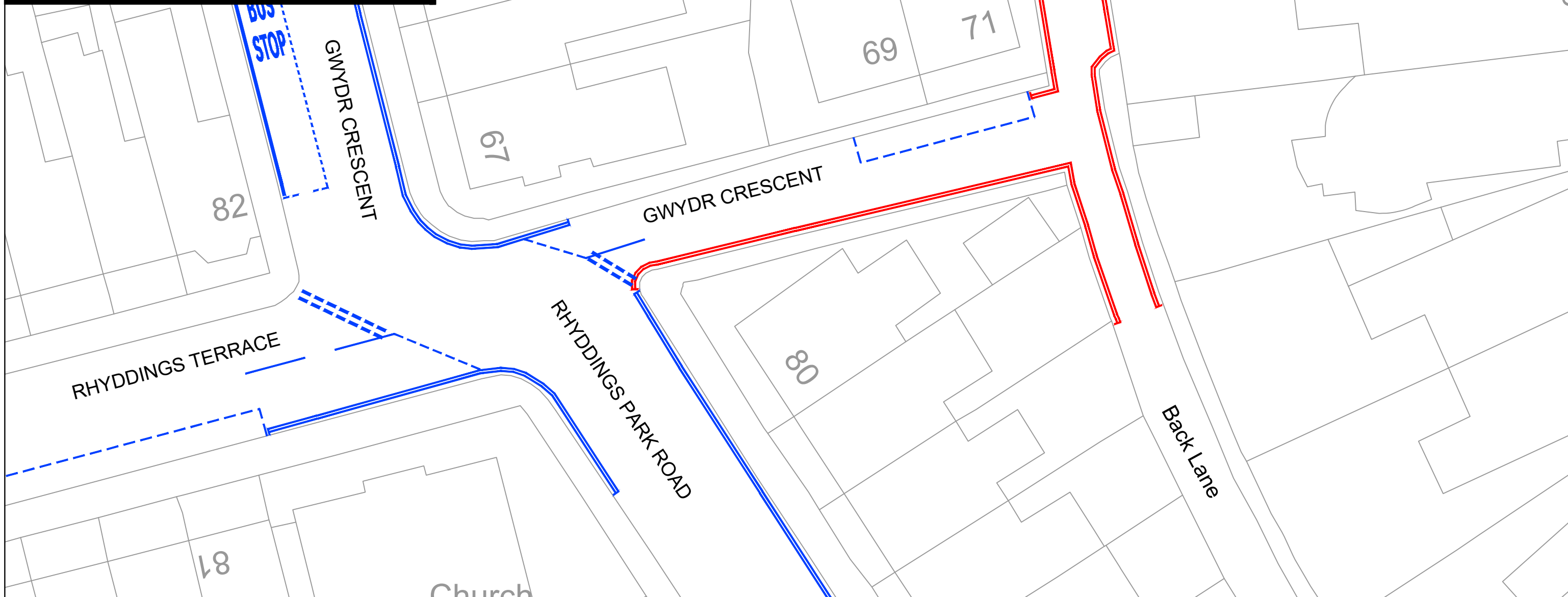
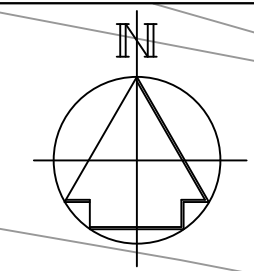

NOTES

1. THIS IS A CAD DRAWING AND SHOULD NOT BE AMENDED BY HAND.
2. All dimensions in millimeters unless otherwise stated.
3. ©Hawlfraint y Goron a hawliau cronfa ddata 2022 Yr Arolwg Ordnans 100023509.  
©Crown Copyright and database rights 2022 Ordnance Survey 100023509.
4. Any errors or omissions to be reported to the Designer.



Existing Traffic Regulation Orders



Proposed Prohibition of Waiting At Any Time.

A3

RHAGARWEINIOL - PRELIMINARY

Dyluniwyd Drawn	JD
Archwiliwyd Checked	AJ
Cymeradwywyd Approved	AF
Dyddiad Date	Sep'22
Graddfa Scale	NTS

Teitl Title	Community Budgets 2022/23 Uplands Area Proposed Traffic Regulation Orders
Gwydr Crescent	



**CYFARWYDDIAETH LLEOEDD**  
**DIRECTORATE OF PLACE**  
STUART DAVIES B.Eng., C.Eng., M.I.C.E., MBA.  
PENNAETH PRIFYRDOD A CHILDANT  
HEAD OF HIGHWAYS & TRANSPORTATION

Rhif y Dyluniad Drawing No	T.22.CB.35.002.06
----------------------------	-------------------

Rev	Date	Details	Dr	Ch	Ap

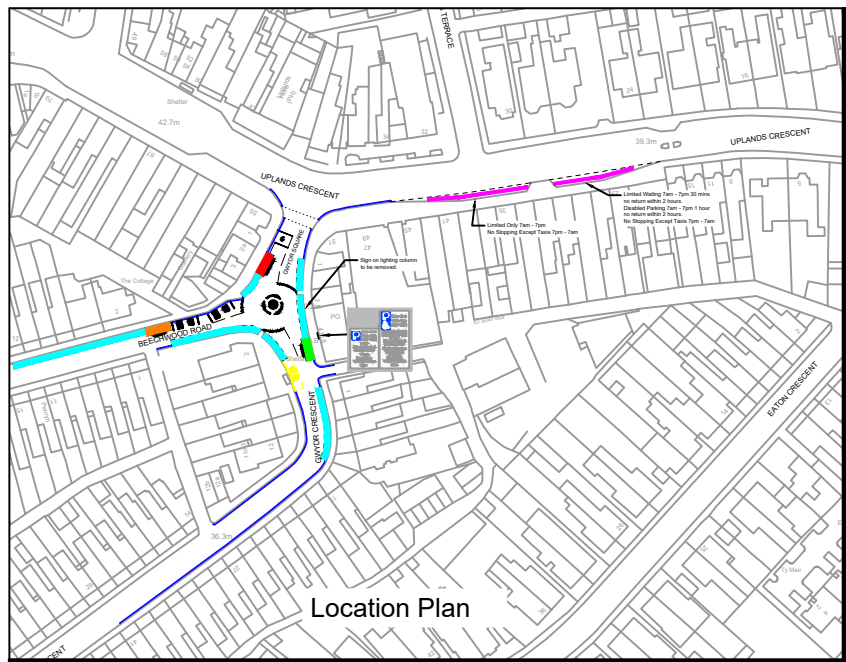

Location Plan

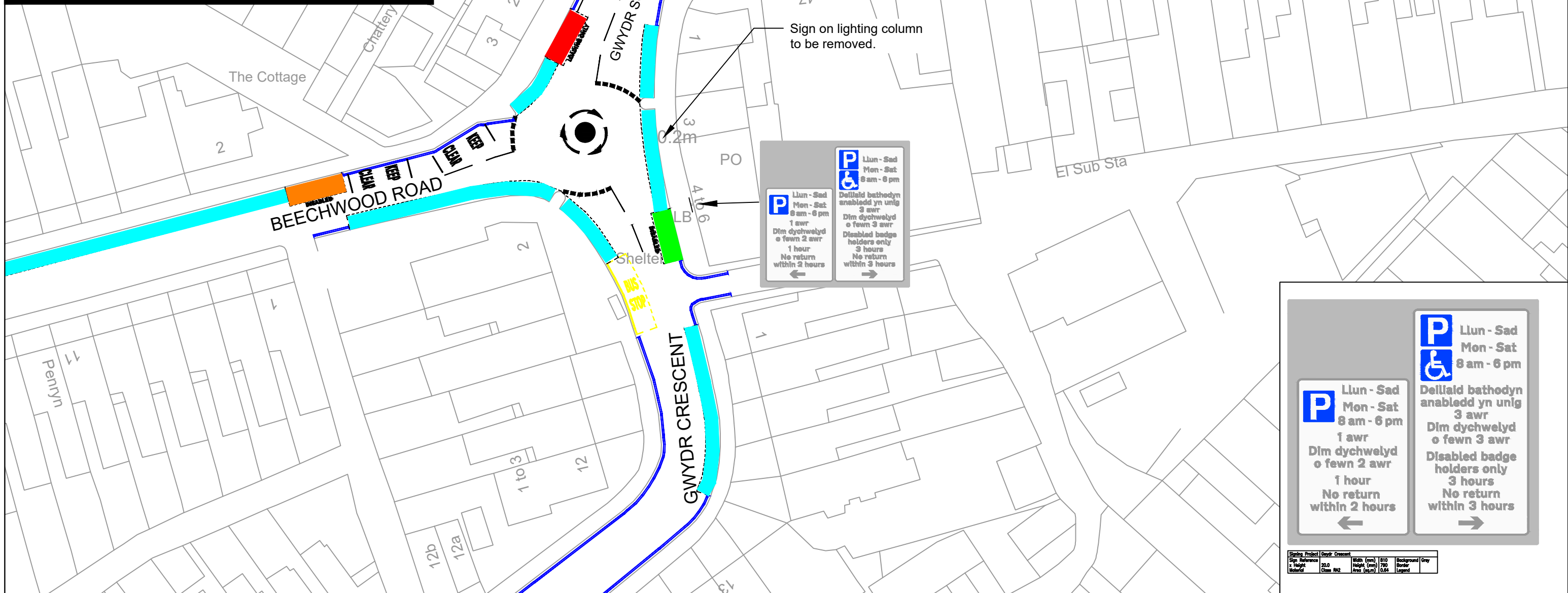

<b>P</b> Llun - Sad Mon - Sat 8 am - 6 pm 1 awr Dim dychwelyd o fewn 2 awr 1 hour No return within 2 hours	<b>P</b> Llun - Sad Mon - Sat 8 am - 6 pm Deddfaid bathedym anedd yn unig 3 awr Dim dychwelyd o fewn 3 awr Disabled badge holders only 3 hours No return within 3 hours
---	--

<b>P</b> Llun - Sad Mon - Sat 8 am - 6 pm 1 awr Dim dychwelyd o fewn 2 awr 1 hour No return within 2 hours	<b>P</b> Llun - Sad Mon - Sat 8 am - 6 pm Deddfaid bathedym anedd yn unig 3 awr Dim dychwelyd o fewn 3 awr Disabled badge holders only 3 hours No return within 3 hours
---	--

Sign Reference	20.0	Width (mm)	510	Background	Grey
Height	20.0	Height (mm)	750	Border	Black
Material	Class R40	Area (sq.m)	0.84	Legend	

NOTES

- THIS IS A CAD DRAWING AND SHOULD NOT BE AMENDED BY HAND.
- All dimensions in millimeters unless otherwise stated.
- ©Hawlfraint y Goron a hawliau cronfa ddata 2016 Yr Arolwg Ordnans 100023509.  
©Crown Copyright and database rights 2016 Ordnance Survey 100023509.
- Any errors or omissions to be reported to the Designer.

- Existing Double Yellow Lines
- Existing Limited Waiting Bays
- Existing Loading Bays
- Existing Disabled Bay
- Existing Bus Bay
- Existing Shared Use Bays
- Proposed Disabled Bay Mon - Sat 8am - 6pm, 3 hours no return within 3 hours

Rev	Date	Details	Dr	Ch	Ap

<b>A3</b>		<b>RHAGARWEINIOL - PRELIMINARY</b>	
Dyluniwyd Drawn	ARJ	Teitl Title	
Archwiliwyd Checked		Community Budgets 2022/23 Uplands Area Proposed Traffic Regulation Orders	
Cymeradwywyd Approved	AF	Gwydr Crescent	
Dyddiad Date	Jan'23	Rhif y Dyluniad Drawing No	
Graddfa Scale	NTS	T.22.CB.35.004_001	

**CYNGOR ABERTAWE SWANSEA COUNCIL**  
CYFARWYDDIAETH LLEOEDD  
DIRECTORATE OF PLACE  
STUART DAVIES B.Eng., C.Eng., M.I.C.E., MBA.  
PENNAETH PRIFYRD A CHILIDANT  
HEAD OF HIGHWAYS & TRANSPORTATION



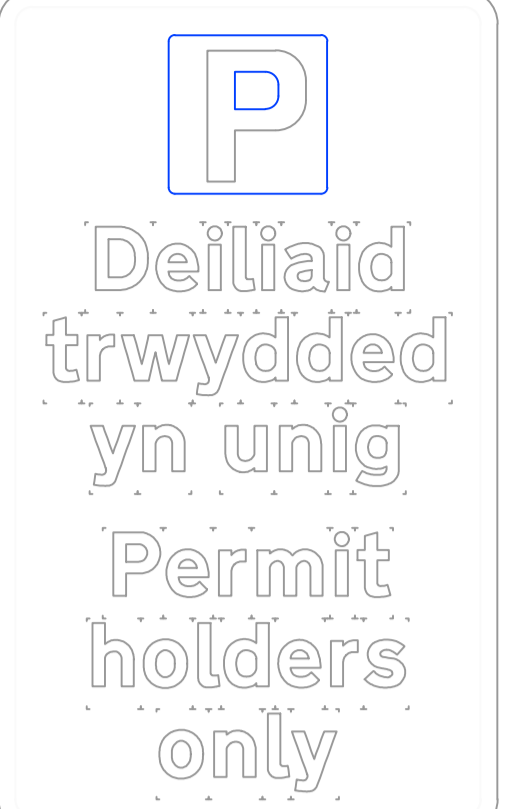

Signing Project	Permit Holders Only - S1				
Sign Reference	TSRGD 660	Width (mm)	220	Background	White
x Height	20.0	Height (mm)	375	Border	Black
Material	Class RA2	Area (sq.m)	0.08	Legend	Black

**NOTES**

1. THIS IS A CAD DRAWING AND SHOULD NOT BE AMENDED BY HAND.
2. All dimensions in millimetres unless otherwise stated.
3. ©Hawfaint y Goron a hawliau cronfa ddata 2023 Yr Arolwg Ordnans 100023509.  
©Crown Copyright and database rights 2023 Ordnance Survey 100023509.
4. Any errors or omissions to be reported to the Designer.
5. All existing Road Markings are to be made good where affected.

**Key**

- Proposed Traffic Regulation Order Permit Holders Only Parking (+ length)
- Location of New Road Sign S2 on New Post
- Location of New Road Sign S2 on Existing Street Lighting Post
- Existing Road Markings

Rev	Date	Details	Dr	Ch	Ap

<b>A1</b>		<b>RHAGARWEINIOL - PRELIMINARY</b>	
Dyluniwyd Drawn	AJD	Community Budget 2023/24 Uplands Ward	
Archwiliwyd Checked	JD		
Cymeradwywyd Approved	ARJ	Proposed Traffic Regulation Order  Cambridge Street, Uplands Swansea	
Dyddiad Date	June '23		
Graddfa Scale	NTS	General Arrangement	
		<b>CYFARWYDDIAETH LLEOEDD</b> <b>DIRECTORATE OF PLACE</b> <small>STUART DAVIES B.Eng., C.Eng., M.I.C.E., MBA.</small> <small>PENNAETH PRIFYRD A CHILDIANT</small> <small>HEAD OF HIGHWAYS &amp; TRANSPORTATION</small>	
		Rhif y Dyluniad Drawing No	T.23.CB.29.001-01
			-

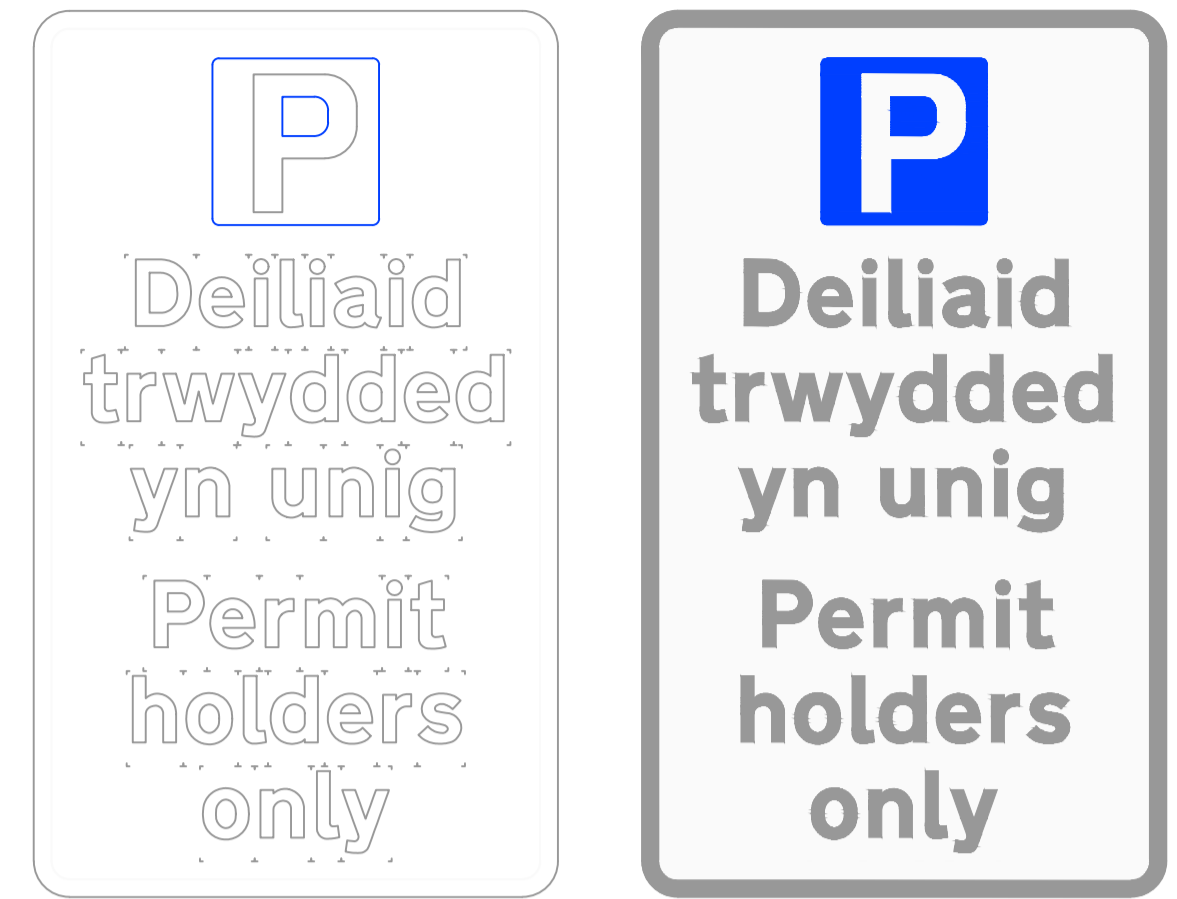
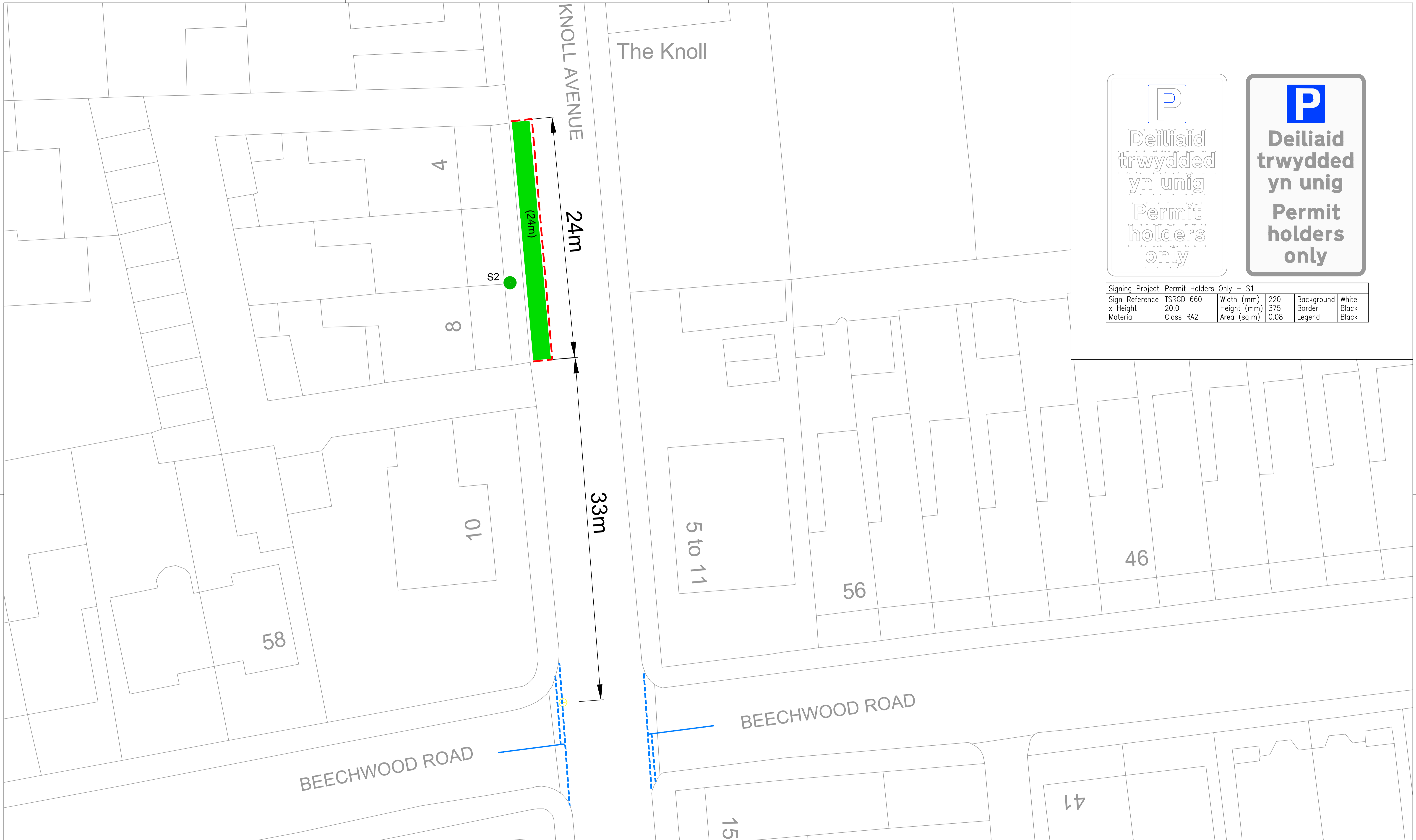

Signing Project	Permit Holders Only - S1				
Sign Reference	TSRCD 660	Width (mm)	220	Background	White
x Height	20.0	Height (mm)	375	Border	Black
Material	Class RA2	Area (sq.m)	0.08	Legend	Black

**NOTES**

1. THIS IS A CAD DRAWING AND SHOULD NOT BE AMENDED BY HAND.
2. All dimensions in millimetres unless otherwise stated.
3. ©Hawffraint y Goron a hawliau cronfa ddata 2023 Yr Arolwg Ordnans 100023509.  
©Crown Copyright and database rights 2023 Ordnance Survey 100023509.
4. Any errors or omissions to be reported to the Designer.
5. All existing Road Markings are to be made good where affected.

**Key**

- Proposed Traffic Regulation Order Permit Holders/Limited Time 1hr Parking (+ length)
- Location of New Road Sign S2 on New Post
- Existing Road Markings

Rev	Date	Details	Dr	Ch	Ap

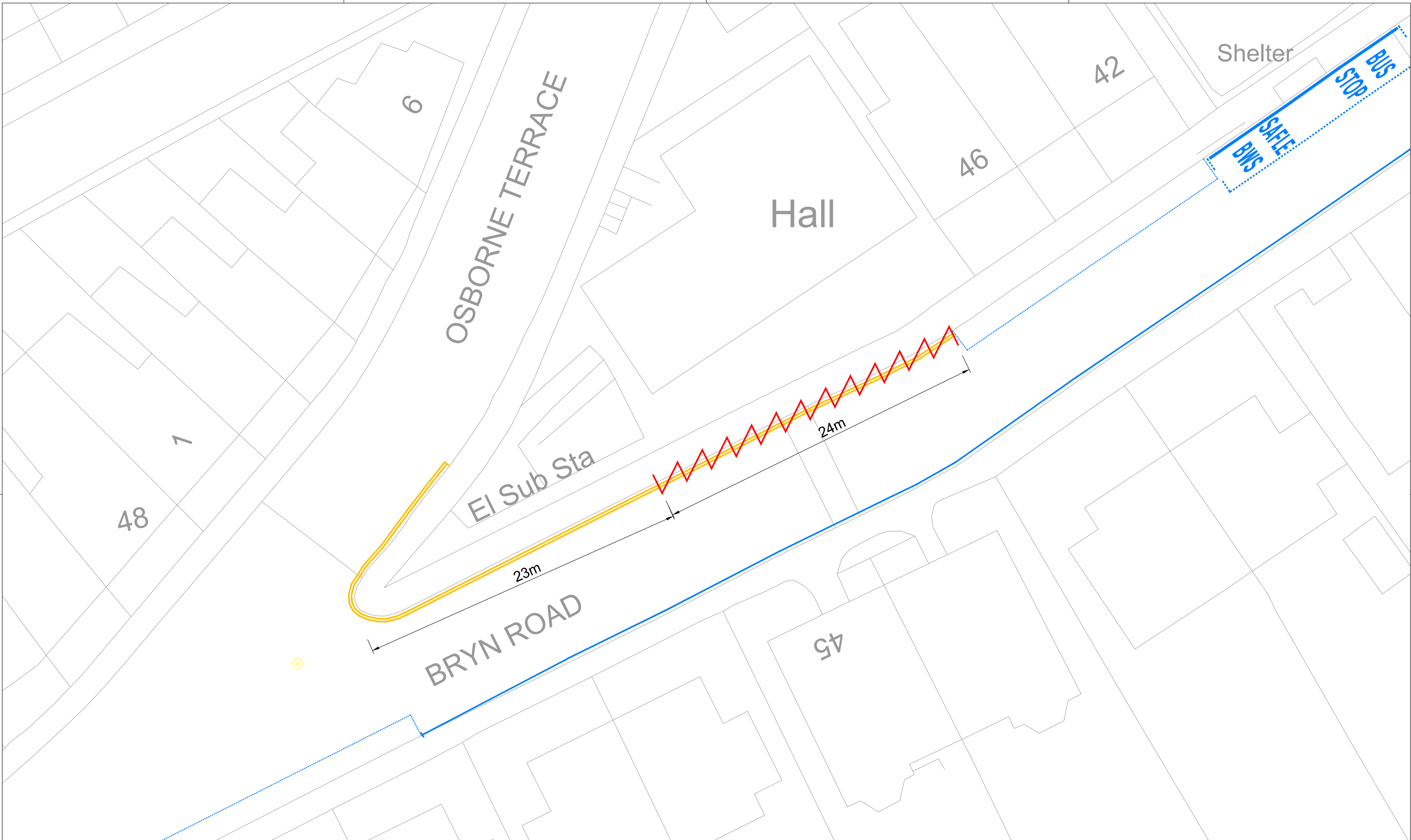

<b>A1</b>		<b>RHAGARWEINIOL - PRELIMINARY</b>	
Dylunwyd Drawn	AJD	Community Budget 2023/24 Uplands Ward	
Archwiliwyd Checked	JD	Proposed Traffic Regulation Order	
Cymerachwyd Approved	ARJ	Knoll Avenue, Uplands Swansea	
Dyddiad Date	June '23	General Arrangement	
Graddfa Scale	NTS	 <b>CYFARWYDDIAETH LLEOEDD DIRECTORATE OF PLACE</b> <small>STUART DAVIES B.Eng., C.Eng., M.I.C.E., MBA, PENNAETH PRIFYRDOD A CHLUDIANT HEAD OF HIGHWAYS &amp; TRANSPORTATION</small>	
Rhif y Dyluniad Drawing No		T.23.CB.29.002-01	-



**NOTES**

1. THIS IS A CAD DRAWING AND SHOULD NOT BE AMENDED BY HAND.
2. All dimensions in millimetres unless otherwise stated.
3. ©Hawffraint y Goron a hawliau cronfa ddata 2023 Yr Arolwg Ordnans 100023509.  
©Crown Copyright and database rights 2023 Ordnance Survey 100023509.
4. Any errors or omissions to be reported to the Designer.
5. All existing Road Markings are to be made good where affected.

**Key**

-  Proposed Traffic Regulation Order Revoke Prohibition of Waiting At Any Time (Double Yellow Lines) 24m
-  Existing Road Markings

Rev	Date	Details	Dr	Ch	Ap

<b>A1</b>		<b>RHAGARWEINIOL - PRELIMINARY</b>	
Dyluniwyd Drawn	AJD	Community Budget 2023/24 Uplands Ward  Proposed Traffic Regulation Order  Bryn Road, Uplands Swansea  General Arrangement	
Archwiliwyd Checked	JD		
Cymeradwywyd Approved	ARJ		
Dyddiad Date	June '23		
Graddfa Scale	NTS		
 <b>CYFARWYDDIAETH LLEOEDD</b> DIRECTORATE OF PLACE <small>STUART DAVIES B.Eng., C.Eng., M.I.C.E., MBA,                  PENNAETH PRIFYRDD A CHLUDGIANT                  HEAD OF HIGHWAYS &amp; TRANSPORTATION</small>		Rhif y Dyluniad Drawing No <b>T.23.CB.29.003-01</b>	-

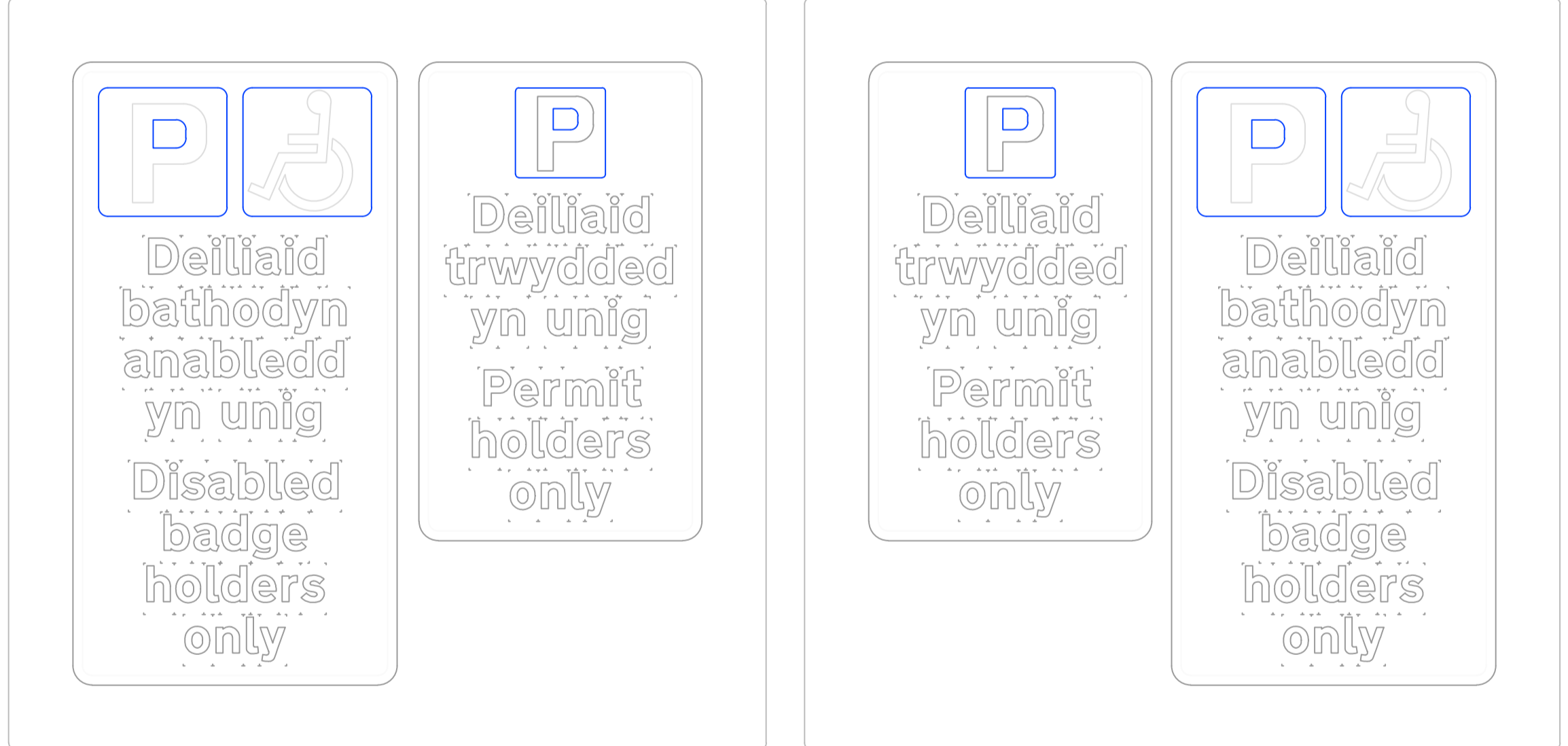
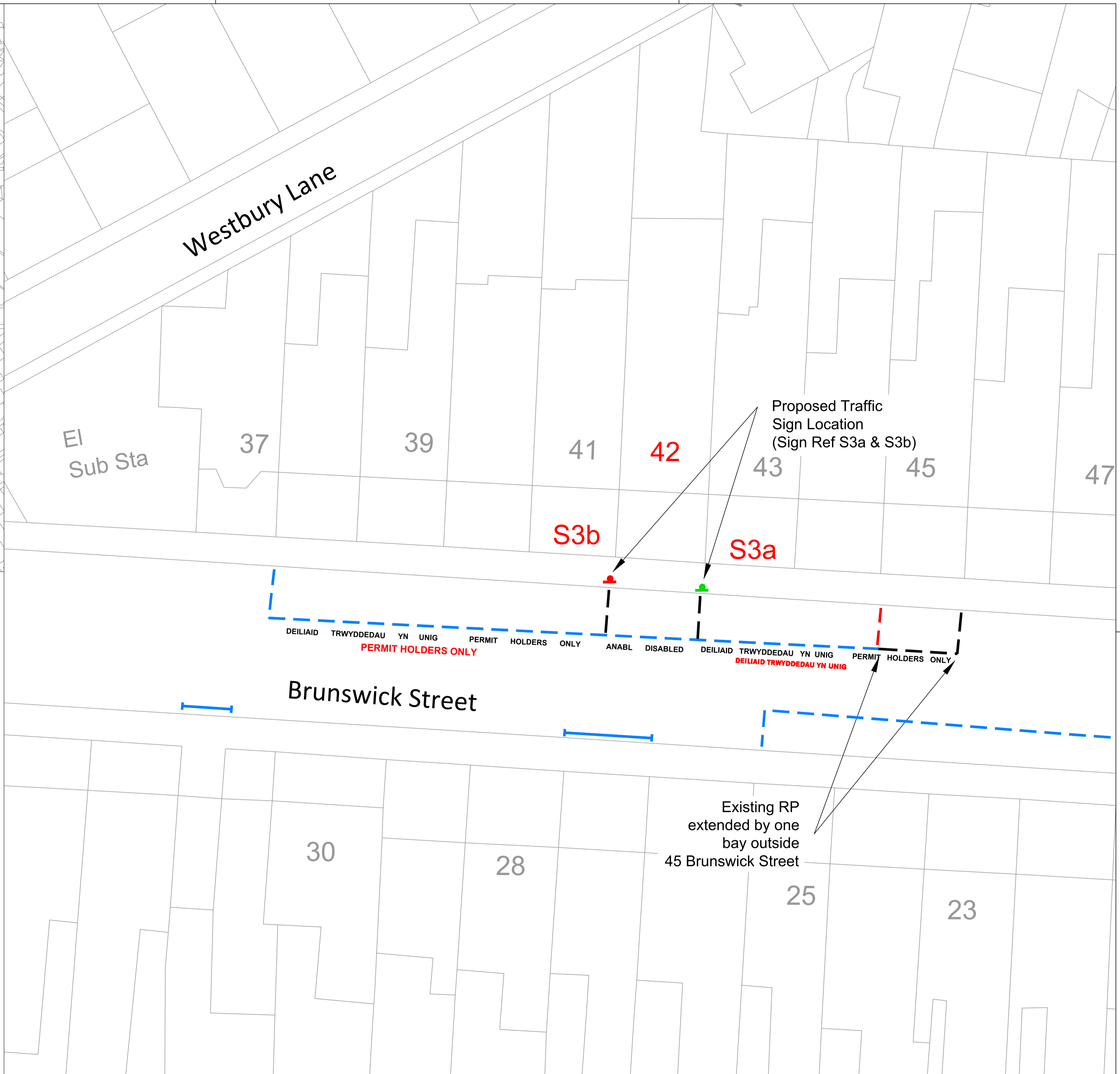
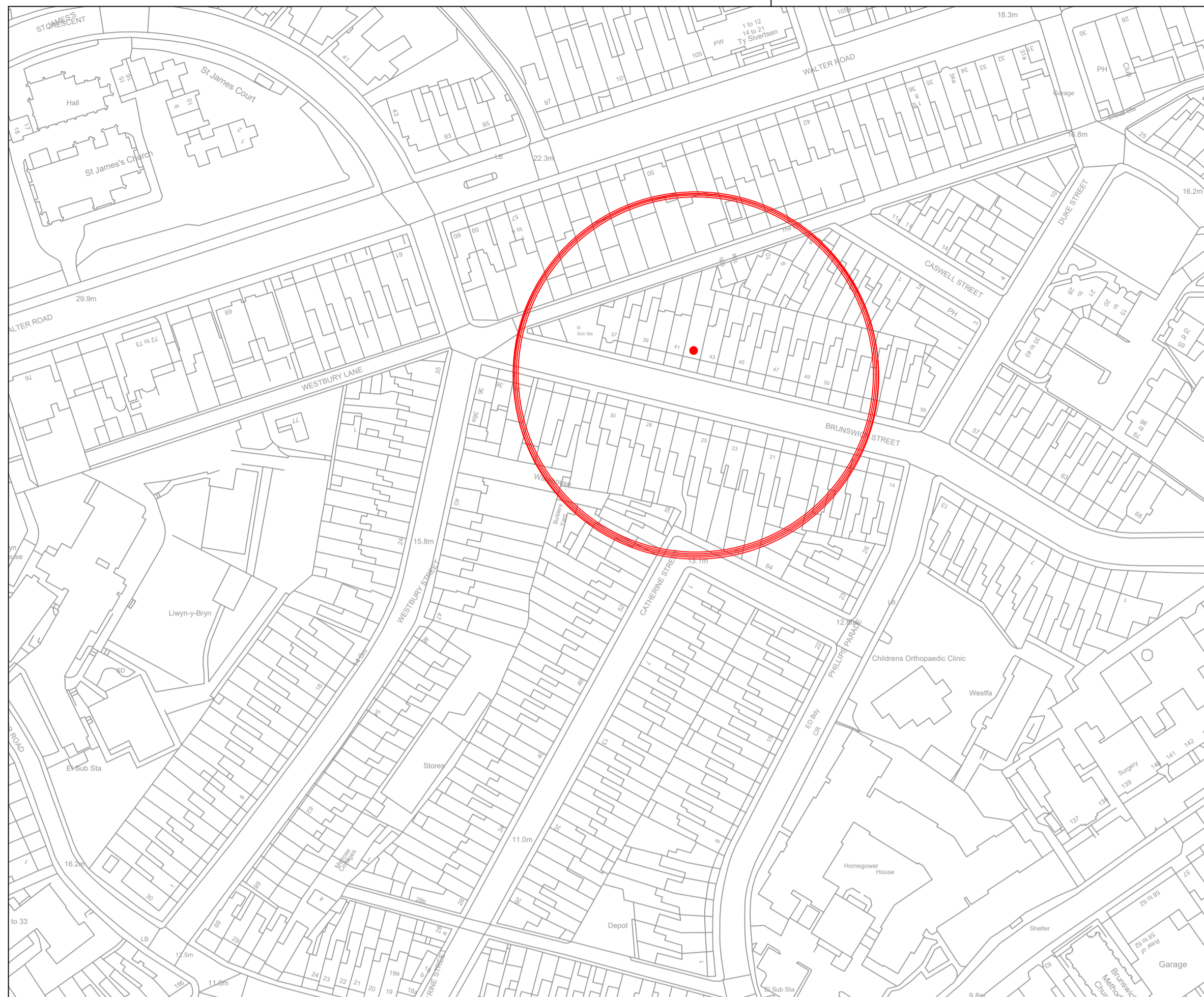

Sign S3a

Sign S3b

Signing Project	Disabled Parking Sign S3a & S3b				
Sign Reference	20.0	Width (mm)	590	Background	Grey
x Height		Height (mm)	585	Border	
Material	Class R3B	Area (m <sup>2</sup> )	0.35	Legend	

**Sign Ref S3a & S3b**  
(1No. of each Sign Required)

**NOTES**

- THIS IS A CAD DRAWING AND SHOULD NOT BE AMENDED BY HAND.
- All dimensions in millimetres unless otherwise stated.
- ©Hawffraint y Goron a hawliau cronfa ddata 2023 Yr Arolwg Ordnans 100023509.  
©Crown Copyright and database rights 2023 Ordnance Survey 100023509.
- Any errors or omissions to be reported to the Designer.
- All existing Road Markings are to be made good where affected.

**KEY**

- New Sign on New Post
- New Sign on existing post
- Road Markings to remain
- Existing Road Markings to be Removed (DPPS TRO revoked)
- New Road Markings
- ANABL DISABLED New Text to be added to Bay outside No. 42
- PERMIT HOLDERS ONLY New Text to be added across RP Bays

<b>A1</b>		<b>RHAGARWEINIOL - PRELIMINARY</b>	
Dylunwyd Drawn	AJD	Trell Title	Community Budget 2023/24 Uplands Ward
Archwiliwyd Checked	JD		Proposed Traffic Regulation Order
Cymerachwywyd Approved	ARJ		42 Brunswick Street, Uplands Swansea
Dyddiad Date	June '23		General Arrangement
Graddfa Scale	NTS		

**CYFARWYDDIAETH LLEOEDD**  
**DIRECTORATE OF PLACE**

STUART DAVIES B.Eng., C.Eng., M.I.C.E., MBA,  
PENNAETH PRIFYRDO A CHLUDANT  
HEAD OF HIGHWAYS & TRANSPORTATION

Rhif y Dyluniad Drawing No

**T.23.CB.29.004-01**

Rev	Date	Details	Dr	Ch	Ap