

THE COUNCIL OF THE CITY AND COUNTY OF SWANSEA
CYNGOR DINAS A SIR ABERTAWE
PROPOSED TRAFFIC REGULATION ORDER
MEADOW STREET, TOWNHILL
WAITING AND DRIVING RESTRICTIONS
NOTICE 2024

NOTICE is hereby given that the Council of the City and County of Swansea intends to make an Order in pursuance of its powers as contained in the Road Traffic Regulation Act 1984 (as amended) (“the Act”) the effect of which is as set out in the Schedule(s) below. A copy of the proposed Order, Statement of Reasons and an appropriate plan may be inspected during normal office hours at the Civic Centre Oystermouth Road Swansea SA1 3SN. Any objections to the proposals should be submitted in writing setting out the reasons thereto to reach the undersigned at the above address or via E-mail at Legal.TrafficNotices@swansea.gov.uk by the 24th December 2024 quoting reference DVT-00279192/AVR.

SCHEDULES

SCHEDULE 1

REVOCATIONS

The existing Orders are revoked insofar as they are inconsistent with the proposals hereinafter contained which relate to the length or lengths of the road or roads referred to in the schedules hereto.

SCHEDULE 2

NO WAITING AT ANY TIME /NO LOADING AT ANY TIME

MEADOW STREET

On its northern eastern side from its junction with the north western kerbline of Heol-y-Gors north westwards for a distance of 16 metres and on that same side from a point 70 metres north west of its junction with the north western kerbline of Heol-y-Gors north westwards for a distance of 8 metres and

On its south western side from its junction with the north western kerbline of Heol-y-Gors north westwards for a distance of 10 metres and on that same side from a point 58 metres north west of its junction with the north western kerbline of Heol-y-Gors north westwards for a distance of 20 metres.

HEOL-Y-GORS

On its north western side from a point 10 metres south west of its junction with the south western kerbline of Meadow Street north eastwards for a distance of 28 metres.

SCHEDULE 3

PROHIBITION OF DRIVING OF ALL MOTOR VEHICLES

MEADOW STREET

From a point 78 metres north west of its junction with the north western kerbline of Heol-y-Gors north westwards for a distance of 3 metres.

3rd December 2024

Tracey Meredith

Chief Legal Officer / Prif Swyddog Cyfreithiol



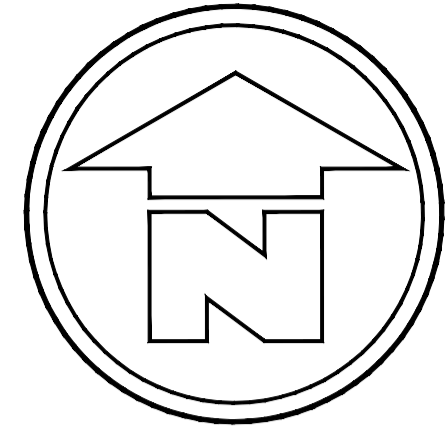

Signing Project	Meadow Street – No Through Road				
Sign Reference	1	Width (mm)	480	Background	Blue
x Height	N/A	Height (mm)	480	Border	White
Material	Class R3B	Area (m ²)	0.23	Legend	N/A

Dim llwytho unrhyw bryd
No loading at any time

Signing Project	Meadow Street				
Sign Reference	20.0	Width (mm)	280	Background	White
x Height		Height (mm)	210	Border	Black
Material	Class RA2	Area (m ²)	0.06	Legend	Black

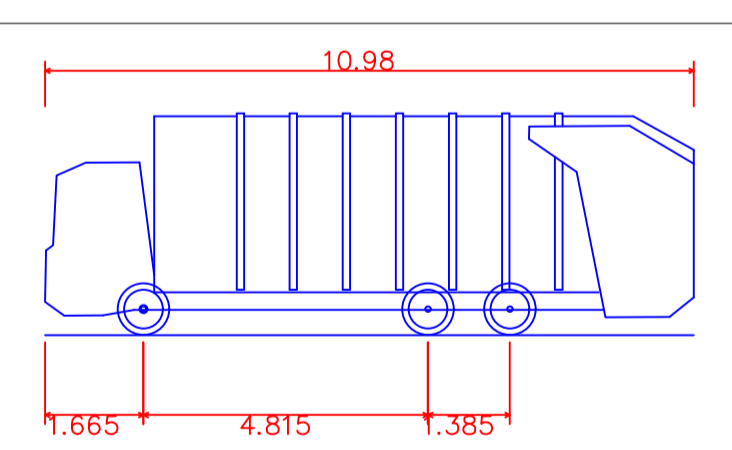

Phoenix 2 One-Pass (with Elite 6x4 chassis)
 Overall Length 10.980m
 Overall Width 2.500m
 Overall Body Height 3.751m
 Min Body Ground Clearance 0.304m
 Track Width 2.500m
 Lock to lock time 4.00s
 Kerb to Kerb Turning Radius 9.000m

NOTES

1. THIS IS A CAD DRAWING AND SHOULD NOT BE AMENDED BY HAND.
2. All dimensions in millimeters unless otherwise stated.
3. ©Hawfraint y Goron a hawliau cronfa ddata 2021 Yr Arolwg Ordnans 100023509.
©Crown Copyright and database rights 2021 Ordnance Survey 100023509.
4. Any errors or omissions to be reported to the Designer.

Rev	Date	Details	Dr	Ch	Ap

JERSEY BARRIER
 "NO WAITING/ NO LOADING AT ANY TIME" ROADMARKINGS
 SIGN POSTS
 UNADOPTED HIGHWAY
 ADOPTED HIGHWAY

A1		RHAGARWEINIOL - PRELIMINARY	
Dylunwyd Drawn	HT	Title	
Archwiliwyd Checked	AFF	Community Budgets 2019/20	
Cymeriwyd Approved	AFF	Meadow Street	
Dyddiad Date	Feb'20	Option C Proposed	
Graddfa Scale	1:500	No through Road	
Rhif y Dyluniad Drawing No		T.19.CB.34.001_001	
C		C	

CYFARWYDDIAETH LLEOEDD DIRECTORATE OF PLACE
 STUART DAVIES - B Eng., C Eng., M.I.C.E., MBA.
 PENNAETH PRIFFFRDD A CHLUDJANT
 HEAD OF HIGHWAYS & TRANSPORTATION

STATEMENT OF REASONS

Notice of Intent for the Traffic Regulation Order

PROPOSED TRAFFIC REGULATION ORDERS MEADOW STREET, TOWNHILL

The provision of a road closure in Meadow Street is to prevent heavy industrial traffic from passing the residential frontages in Meadow Street.

The provision of waiting restrictions in the residential part of Meadow Street and on the corner with Heol-y-Gors is to assist refuse vehicles to access the new cul-de-sac section of Meadow Street.

Extract from RTRA 1984

2 What a traffic regulation order may provide.

(1) A traffic regulation order may make any provision prohibiting, restricting or regulating the use of a road, or of any part of the width of a road, by vehicular traffic, or by vehicular traffic of any class specified in the order,—

(a) either generally or subject to such exceptions as may be specified in the order or determined in a manner provided for by it, and

(b) subject to such exceptions as may be so specified or determined, either at all times or at times, on days or during periods so specified.

**THE COUNCIL OF THE CITY
AND COUNTY OF SWANSEA
CYNGOR DINAS A SIR ABERTAWE**



**TRAFFIC REGULATION ORDER
MEADOW STREET, TOWNHILL
WAITING AND DRIVING RESTRICTIONS
ORDER 2024**

DVT-00279192/AVR

**THE COUNCIL OF THE CITY
AND COUNTY OF SWANSEA
CYNGOR DINAS A SIR ABERTAWE
TRAFFIC REGULATION ORDER
MEADOW STREET, TOWNHILL
WAITING AND DRIVING RESTRICTIONS
ORDER 2024**

THE COUNCIL OF THE CITY AND COUNTY OF SWANSEA (hereinafter called “the Council”) in exercise of its powers under the Road Traffic Regulation Act 1984, as amended (hereinafter referred to as “the 1984 Act”), the Traffic Management Act 2004 (“the 2004 Act”), the Local Government (Miscellaneous Provisions) Act 1976 (“the 1976 Act”) and all other enabling powers, and after consultation with the Chief Officer of Police in accordance with Part III of Schedule 9 and Section 124 of the 1984 Act hereby makes the following Order.

SECTION 1 – PRELIMINARY

Citation and commencement

1. This Order shall come into operation on XX XXXXXX 2024 and may be cited as the Council of the City and County of Swansea, Meadow Street, Townhill (Waiting and Driving Restrictions), Swansea Order 2024.

Definitions

2. In this order, except where the context otherwise requires, the following expressions have the meaning hereby respectively assigned to them:

“Civil Enforcement Officer” has the same meaning as in Section 63A of the 1984 Act and by virtue of Section 76 of the 2004 Act a Civil Enforcement Officer appointed under Section 63A of the 1984 Act is a Civil Enforcement Officer in relation to parking contraventions;

“Disabled Person’s Vehicle” has the same meaning as in the Local Authorities’ Traffic Orders (Exemption for Disabled Persons) (Wales) Regulations 2000;

“Disabled Person’s Badge” has the same meaning as in the Disabled Persons (Badges for Motor Vehicles)(Wales) Regulation 2000;

“Exempted Vehicles” means:

- (a) any vehicle being used by the emergency services for the purposes described in section 87 of the Road Traffic Regulation Act 1984(1) ;
- (b) any Vehicles being used for naval, military or air force purposes, and being driven by a person for the time being subject to the orders of the member of the armed forces of the crown, who is a member of the special forces-
 - (i) in response, or for a practice in responding, to a national security emergency by a person who has been trained in driving at high speeds, or
 - (ii) for the purpose of training a person in driving vehicles at high speeds;

“Parking Disc” means a disc and time clock (where appropriate) issued by a local authority complying with the requirements of the British Standard Specifications for Parking Discs to comply with the European Blue Badge Scheme being a disc coloured blue and capable of showing the quarter hour period during which a period of waiting begins;

“Relevant Position” in respect of:-

- (a) a Disabled Person’s Badge and parking disc has the same meaning as in the Local Authorities’ Traffic Orders (Exemptions for Disabled Persons) (Wales) Regulations 2000; and
- (b) a Waiver means exhibited on the windscreen, dashboard or fascia of the vehicle or, where the vehicle does not have a windscreen, dashboard or fascia, in a conspicuous position on the vehicle so that the whole of the information on the front of the waiver is clearly legible from outside the vehicle;

“Waiver” means a Waiver issued by the Council in respect of vehicles being used for building maintenance repair shop fitting or other industrial or demolition operations and the Council may charge for such waiver such charge to be determined from time to time by resolution of the Council or relevant Committee thereof;

Interpretation

3. Except where otherwise stated, any reference in this Order to a numbered Article or Schedule is a reference to the Article or Schedule bearing that number in this Order

4. The Interpretation Act 1978 shall apply for the interpretation of this Order as it applies for the Interpretation of an Act of Parliament
5. The prohibitions and restrictions imposed by this Order shall be in addition to and not in derogation of any other prohibition or restriction whether made under the 1984 Act or otherwise

SECTION 2 – NO WAITING AT ANY TIME /NO LOADING AT ANY TIME

6. Save as provided in Article 7 no person shall, except upon the direction or with the permission of a Civil Enforcement Officer, police officer in uniform, or a person authorised by the Council, cause or permit any vehicle to wait at any time on the length or lengths of the road or roads referred to in Schedule 2 hereto.

Exemptions

7. Nothing in Article 6 of this Order shall render it unlawful to cause or permit any vehicle to wait on the side or sides or length or lengths of the road or roads specified therein for as long as may be necessary to enable:-
 - (a) the vehicle, if it cannot conveniently be used for such purpose in any other road, to be used in connection with any of the following operations namely:-
 - (i) building, maintenance, repair, shop fitting or other industrial or demolition operations with a Waiver issued by the Council and displayed in the Relevant Position on the windscreen of the vehicle;
 - (ii) the removal of any obstruction to traffic;
 - (iii) the laying, erection, alteration or repair in or on land adjacent to the said lengths or sides of the road of any sewer or any main pipe or apparatus for the supply of water, gas electricity or of any telecommunications apparatus as defined by the Telecommunications Act 1984; or
 - (iv) a vehicle being used for police, ambulance, fire brigade or other emergency purposes;

- (b) the vehicle if it cannot conveniently be used for such purpose in any other road, to be used in connection with the service of a local authority or of a water authority in pursuance of its statutory powers and duties; or
- (c) the vehicle of the Royal Mail or other universal services provider as defined in Section 27 of the Postal Services Act 2011 to be used for the purpose of delivering or collecting mail.

SECTION 3 – PROHIBITION OF DRIVING OF ALL MOTOR VEHICLES

- 8. Save as provided in Article 9 no person shall, except on the direction of a Police Officer in uniform or a person authorised by the Council no person shall cause any Motor Vehicle to enter the roads at their junctions as referred to in Schedule 3 hereto.

Exemptions

- 9. Nothing in Article 8 shall apply in respect of Exempted Vehicles.

REVOCATION

- 10. The existing Orders are revoked insofar as they are inconsistent with the proposals contained in the schedules hereto and insofar as they relate to the length or lengths of the road or roads referred to in the Schedule hereto.

SCHEDULES

SCHEDULE 1

REVOCATIONS

The existing Orders are revoked insofar as they are inconsistent with the proposals hereinafter contained which relate to the length or lengths of the road or roads referred to in the schedules hereto.

SCHEDULE 2

NO WAITING AT ANY TIME /NO LOADING AT ANY TIME

MEADOW STREET

On its northern eastern side from its junction with the north western kerbline of Heol-y-Gors north westwards for a distance of 16 metres and on that same side from a point 70 metres north west of its junction with the north western kerbline of Heol-y-Gors north westwards for a distance of 8 metres and

On its south western side from its junction with the north western kerbline of Heol-y-Gors north westwards for a distance of 10 metres and on that same side from a point 58 metres north west of its junction with the north western kerbline of Heol-y-Gors north westwards for a distance of 20 metres.

HEOL-Y-GORS

On its north western side from a point 10 metres south west of its junction with the south western kerbline of Meadow Street north eastwards for a distance of 28 metres.

SCHEDULE 3

PROHIBITION OF DRIVING OF ALL MOTOR VEHICLES

MEADOW STREET

From a point 78 metres north west of its junction with the north western kerbline of Heol-y-Gors north westwards for a distance of 3 metres.

Dated this

THE COMMON SEAL OF THE)
COUNCIL OF THE CITY AND)
COUNTY OF SWANSEA)
was hereunto affixed)
in the presence of)

Authorised Signatory

DRAFT